

Automated irrigation system using a wireless sensor network and GSM module

Femila Roseline J*, Sree Kala J.C, Kasa Ishwarya

Department of Electrical and Electronics Engineering, Sathyabama University, Chennai.

*Corresponding author: E-Mail: femila14@yahoo.com

ABSTRACT

An automated irrigation system is developed to reduce the usage level of and to reduce power loss in agricultural fields. The system has of soil-moisture sensor, temperature sensor, water availability sensor, level sensor, EB power availability sensor. In addition, this automated system gives the sensor information, triggering signals to the actuators and also transmits the data through SMS to the farmer. A FUZZY based algorithm is developed with set values of temperature and soil moisture and level of water that is programmed into a microcontroller-based controller system to control the usage of water. A GSM modem is used to transmit about the condition of crop along with various sensors. Because of its energy efficiency and lowest cost, this automated system has to be useful in the areas where the ground water level is less like a geographically isolated areas.

KEY WORDS: PIC Microcontroller, Temperature sensor, Moisture sensor, Water availability sensor, Water level sensor, EB Power availability sensor, GSM module.

1. INTRODUCTION

The agricultural fields require water supply at regular intervals for very good yields of food production and the water will be supplied to the farms from the nearby motor pumps. These pump sets have to be switched on and the water from this pump will be directed to the fields through the small canals and the motor has to be switched off after the field is sufficiently wet.

To do that, a person has to be employed exclusively to switch on the motor to supply water to the farms and switch off the motor after a certain amount of time. If the person is unable to go to the farm and switch on the motor on a particular day, the fields will be dry and the yield may not be a good one. To avoid that and make the system a completely automated one, an automated irrigated system has been developed to control the motor so as to supply the water to the farms at a particular interval and also to provide the status information of the motor to the user. The farmer can sit at one present place and monitor the field.

No cabling or hardware connections are required to do this. Everything will be carried out in a wireless fashion and this system is entirely an automated product.

Related Work: Sunil Kumar (2014), proposed an Automatic irrigation system using wireless sensor network and GPRS module. They have developed an automated irrigation system based on ARM microcontroller. Optimum use of water was main objective of their irrigation system to reduce water consumption. They have used temperature and soil moisture sensors to detect the amount of water present in agriculture and water level sensor to detect water level in over head tank. And also they have monitored the status of the sensors on remote PC through a web page. They have the temperature and soil moisture sensors and water level on web page through micro controller. The web-server was connected to the internet. By typing the IP-address on the web browser, the owner gets a web page on screen. Siva Sankari (2014), proposed a wireless monitoring and controlling system for automatic irrigation field. They have controlled the motor operation by sensing the soil moisture content which was sensed by the separate sensor. Sensor output data had fed into the micro controller and the microcontroller acted according to the control algorithm. They had used two GSM modules in the network which could be acted as a transmitter and a receiver. Here when a particular moisture level reaches below the threshold value, the motor will be turned ON. The soil moisture content and the motor functionality status can be monitored in Lab VIEW. Deepak Dharrao (2015), proposed an automatic irrigation system using WSN. They had controlled the humidity and temperature of plants precisely by using the sensors. They had implemented the irrigation control system in real time by using microcontroller and GSM (Global System for Mobile Communication) mobile phone. The information had been passed to the user in the form of SMS. Gao Liai (2012), proposed an intelligent irrigation system based on wireless sensor network and fuzzy logic control to resolve the problems which include loss of soil fertility and waste of water resource in agriculture production. The system consisted of wireless sensor networks and the monitoring center. They had taken soil moisture content deviation and the rate of change of deviation as input variables of fuzzy controller and had established a fuzzy control regular database for the fuzzy irrigation control system. The monitoring center received the data transmission from wireless sensor network node and output information of irrigation water demands to the relay via a wireless sensor network to control opening and closing time of the valve in crop areas. The experimental results showed that the system had a stable and reliable data transmission which can be achieved in real-time monitoring of soil on crop growth and gave a right amount of information based on crops growth. Pavithra (2014), proposed a GSM based automatic irrigation control system for efficient use of resources and crop planning

by using an android mobile. They had designed an Android Software Development Kit using Java programming language. They had used GPRS (General Packet Radio Service) as a solution for irrigation control system and GSM (Global System for Mobile Communication) to inform the user about the exact field condition while developing the application.

2. METHODS & MATERIALS

Methodology of Proposed System:

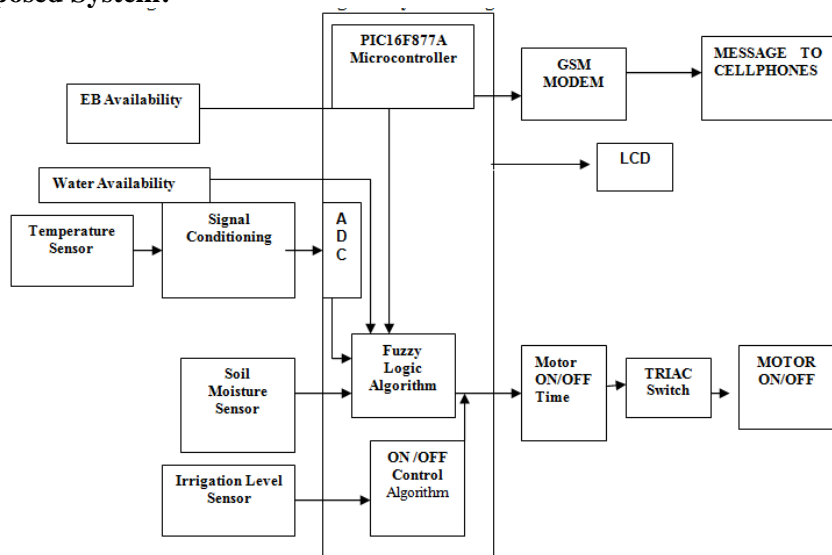

Figure.1. Block diagram of automated irrigation system

The block diagram of the proposed automated irrigation system is shown in figure.1. It consists of five varieties of sensors namely Temperature sensor, Water availability sensor, EB power availability sensor, soil moisture sensor and irrigation level sensor which are connected to the PIC microcontroller. Program based on FUZZY logic algorithm is given to the PIC microcontroller which will act as human brain. The readings from the temperature sensor are in analog form. These can be converted into digital form by using ADC converter which is internally present in the microcontroller. The irrigation level sensor acts as a closed loop operation to the system. The output side of microcontroller consists of Motor On/Off and GSM modem. GSM modem is connected to microcontroller where all information about crop's condition will be gathered from sensors and message will be sent to farmer's cell phone.

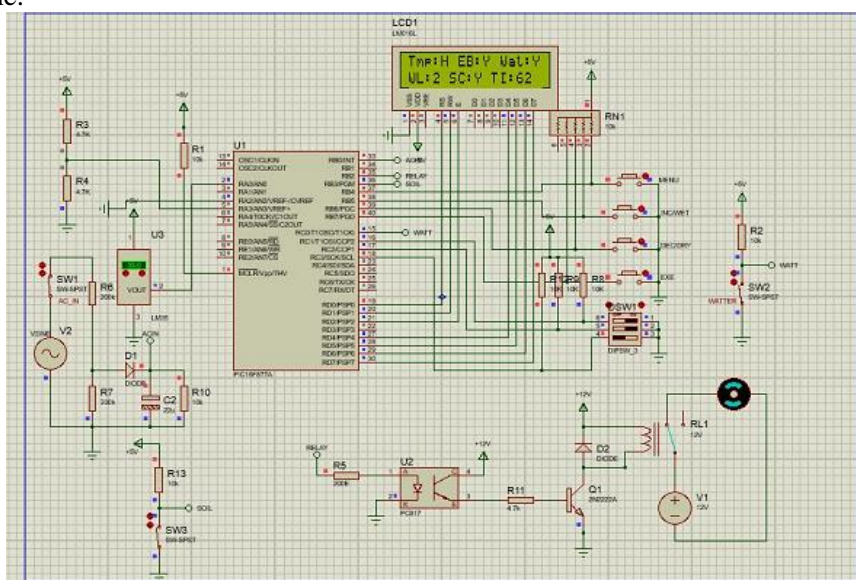

Figure.2. Simulation diagram of automated irrigation system

Figure.2, shows the simulation diagram of an automated irrigation system done in proteus 8. First the system checks whether power supply and water availability in the well are available or not by using EB power supply sensor and water availability sensor. If both are present then wet crop or dry crop can be selected. Based on the crop, the system will operate. If wet crop is selected then it will ask up to which water level the motor should run then it compares between temperature and water level in the field. In this system three levels of water can be selected in the field. By using fuzzy logic algorithm, crisp values are converted into fuzzified values by the process called

fuzzification. Here the inputs are water level and temperature. Each inputs are partitioned into three different membership functions such as low, medium, high. The output is the turn on time of the motor that will also partitioned by three membership functions such as slow, medium and high. Here the triangular membership functions are used as a shape of the membership function. If then rules are applied for the membership functions and then fuzzified outputs are converted into crisp value by the process called defuzzification. Depends upon the output of the crisp values motor turn on time will be decided.

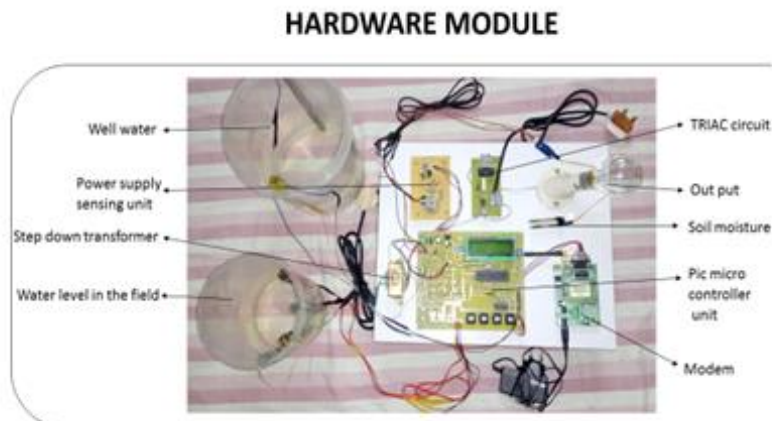

Figure.3. Hardware module of an Automated Irrigation system

Figure.3, shows the hardware module of an automated irrigated system using a wireless sensor network and GSM module. Here a 230v taken from main supply is converted into 9v through step down transformer. This 9v is passed through bridge rectifier circuit which consists of set of four diodes which converts AC to DC and passes through capacitive filter circuit to reduce ripples. Then regulator is used to regulate 9v to 5v as all the components in microcontroller section can take only 5v supply. There are five type of sensors are used namely temperature sensor, soil moisture sensor, EB power availability sensor, water availability sensor and irrigation level sensor. Thermistor is used as temperature sensor which senses atmospheric temperature. EB power availability sensor circuit is operated to check whether supply is there or not by using Opto coupler. Water in well will be sensed through water availability sensor and water level in the field will be sensed through level sensor. Soil moisture sensor is used to sense moisture in the field. All the information sensed will be controlled by microcontroller. Microcontroller is given a program developed in CCS compiler. The software that supports the programmer is WINPIC800. Microcontroller sends all the information to TRIAC section which decides whether to switch ON and switch OFF the motor.

3. RESULTS AND DISCUSSION

Two lines LCD displays is used to display different parameters like temperature, EB availability, water availability, water level in field, soil condition and timer. A GSM modem is employed to send information to the farmer through SMS about condition of agricultural field which is shown in figure.4. So without going to the field farmer can get the information about crop condition.

SCREENSHOOT OF SMS SEND TO THE MASTER

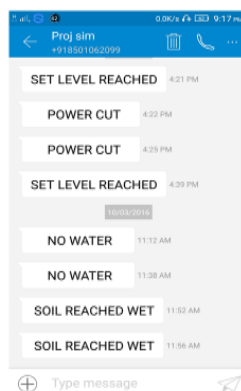

Figure.4. Screen shot of SMS

Table.1. Performance of an Automated Irrigation system

Current temperature	Soil condition	Motor on time (sec)
Low	Wet	0
Low	Dry	60
Medium	Wet	3
Medium	Dry	70
High	Wet	5
High	Dry	100

Table.1, shows the results of an automated irrigation system. Here current temperature and soil conditions are the inputs. Motor on time is the output. Depends upon the condition of the temperature and soil condition, motor turn on time is decided.

4. CONCLUSION

The automated irrigation system implemented was found to be feasible and cost effective for efficient water usage and optimize the electrical power consumption for better crop yield. This irrigation system allows cultivation in places with water scarcity thereby improving sustainability. And also GSM modem will send the information about the condition of the agricultural field through SMS to the farmer.

REFERENCES

- Deepak Dharrao, Laxman Kolape, Sanjeet Pawar and Aniket Patange, Automated Irrigation System using WSN, Asian Journal of Engineering and Technology Innovation, 3 (6), 2015, 18-21.
- Gao Liai and Cheng Man, The design of greenhouse environment detection system based on solar-powered, World Automation congress, Puerto Vallarta, Mexico, 2012.
- Pavithra DS and Srinath MS, GSM based Automatic Irrigation Control System for Efficient use of Resources and Crop Planning by using an Android Mobile, Journal of Mechanical and Civil Engineering, 11 (4), 2014, 49-55.
- Siva Sankari S and Mary Jansi Rani A, Wireless Monitoring and Controlling Automatic Irrigation Field, International Journal of Advanced Research in Electrical, Electronics and Instrumentation Engineering, 3 (12), 2014.
- Sunil Kumar HU, Kusuma SM, Automated Irrigation System Based on Wireless Sensor Network and GPRS Module, International Research Journal of Engineering and Technology (IRJET), 03 (04), 2016.