

Automatic tablet blister sorting system using Image Processing

Ranjith Pillai R*, Suraj Gupta, Hirdesh Raj

SRM University, Kattankulathur, Chennai

*Corresponding author: E-Mail: ranjithpillai.r@ktr.srmuniv.ac.in

ABSTRACT

Industrial automation deals primarily with the automation of manufacturing, quality control and material handling process. The pharmaceutical industries also indulged in using Mechatronics systems for making their production process automated and less of defects. Due to high rate of production, the automation finds its application in packaging process of drug blisters with accuracy in numbers. The count of drug blisters in the boxes should not vary with the desired value as the quantity is one of the parameter that determines the overall equipment efficiency (OEE) of the manufacturing process. The paper deals with the algorithm for counting the drug blisters packed in boxes using image processing. The series of process involves image enhancement, thresholding, segmentation, filtering, subtraction and region based statistic to inspect the boxes of drug blisters in conveyer line.

KEY WORDS: automation, blister sorting, image processing.

1. INTRODUCTION

In the fast-paced pharmaceutical market, automation is an important trend, more so because the pharmaceutical industry is highly regulated since public health safety is of primary importance. Strict pharmaceutical quality and safety standards such as the American Food and Drug Administration's (FDA) Process Analytical Technology (PAT) guidance, as well as Good Manufacturing Practice (GMP) set the framework for pharmaceutical manufacturing processes. They aim at reducing the risk of product recalls and, most importantly, are designed to safeguard consumers' welfare. In order to comply with these regulations, the industry requires reliable and high-end inspection technology equipment to be integrated in their production lines. The work describes the online drug blister sorting system using image processing.

The overall system is comprised of the combination of the mechanical, electrical, and electronics components controlled by the main control unit of the system. The conveyor loads the packed medicine box and transports it along its length. When the box reaches the IR sensor, the IR sensor returns a voltage. This is configured such that it is taken to mean a detection if it is greater than 2.5 mV. Once the object has been detected, the controller sends the data to the computer system which issues a pause command through the controller after 0.2 seconds which allows the box to reach under the vision sensor. The vision sensor captures an image, and sends it to the computer system for image processing. The subsequent operation depends on the result of image processing. If the number of strips equals the required number (10 in the test cases), the conveyor continues on with the box. If the number of strips is found to be different, the computer issues a command to the controller, which sends an actuating signal to the servo motor, which forces the box out of the conveyor system.

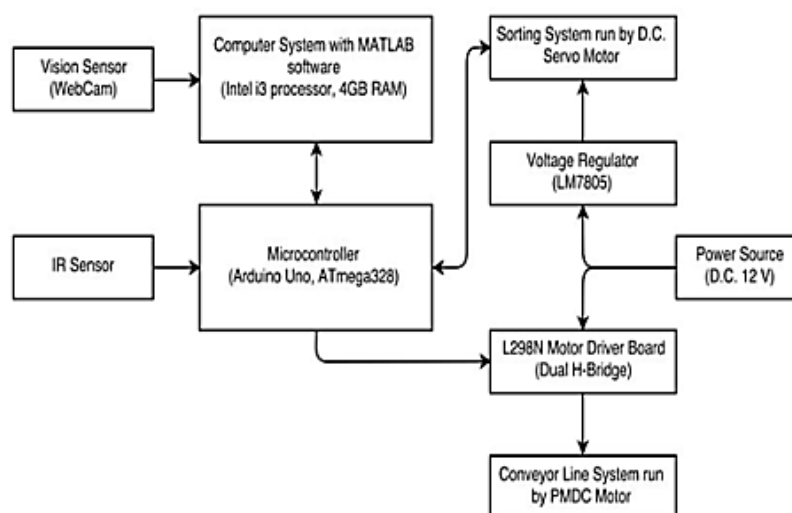

Figure.1. System Structure

2. PROPOSED WORK

The proposed work can be categorized as following sub categories.

Overview of the system: A mechatronics design approach has been presented which carefully integrates various elements of the system such as the mechanisms, actuators, sensors and the electronic controller. The

control signal to the various actuators has been generated using the output of the Image Processing done on the blister image. The steps involved in working of the system is shown in the Fig 2. The conveyor line is loaded with the boxes full of blisters and passed through the inspection unit followed by the image processing. The result of image processing is further used by controller to generate a control signal to the servo actuator in order to sort the boxes out of the conveyor system when the count value of the blisters in the boxes does not match to the desired value.

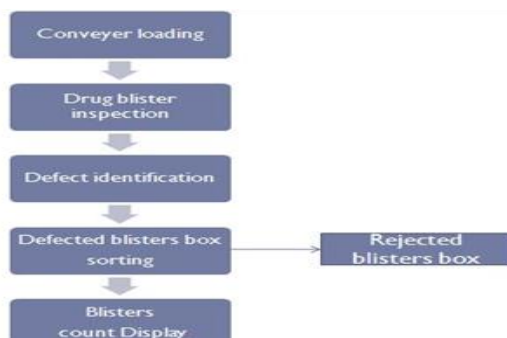

Figure.2. Overview of the setup

Hence display the count values of box inspected on the display unit of a system.

Mechanical Design and Set up: The design of the proposed setup is aimed at being efficient in both acquisition of images and sorting of the blister boxes on the basis of the controlled output from the control unit. The different sub-systems are modeled in order to control the characteristics of inspection of the blister boxes using image processing. These sub-systems are controlled using the combination of mechanical hardware and electrical & electronic control. Another sub-system, which controls the inspection of the drug blisters is the automated conveyor line system and is interfaced with the image processing unit successfully with the help of microcontroller board and other electrical actuators used for sorting purpose. All CAD models have been developed using Solid Works 3D part modeling and assembly software as shown in Fig.3

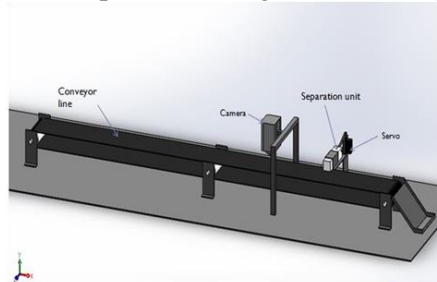

Figure.3. CAD model of proposed Mechanical system

The material and size specification of the conveyor system and base support is given in the following table.1.

Table.1. Structure material and dimension

Components and Parts	Material Selection	Dimensions (mm)
Conveyor belt	Fabric	100mm width; 2mm thickness
Conveyor Roller	Polypropylene	40mm dia
Roller mounts	Mild Steel	3mm thick plate
Camera mounting support	Aluminum alstruts	30mm edge length
Servo actuator or sorting unit mounting	Mild Steel	3mm thick plate

Camera and IR sensor mount: As the positioning and stability of camera is one of the major issues in Image Processing technique thus, proper support and base is required. The focus of the camera can be adjusted by changing the height to which camera is clamped as well as by changing the focus of the lens provided in the webcam. This mount is introduced in the system to provide a support to the camera and the IR sensor module used in the system. In this system Aluminum alstruts of size 30mm×30mm is used for the firm support with the base so that the shaking of the camera can be avoided. The top member of the camera mount is made adjustable to change the height of the camera but for this application the height is fixed as 400mm from the base. The IR sensor is positioned in such a way that the presence of blister box is realized and makes the conveyor belt stop so that the camera can capture the image of the top of the blister box and further send it for processing.

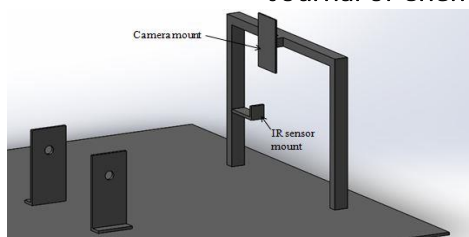

Figure.4. CAD model showing camera and sensor mount

Methodology: The objects have been identified using the various morphology and segmentation operations like dilation, erosion, opening and closing. The flow chart of operations which highlight the main steps involved in image processing is shown in Fig.5. The image processing steps shown in the flow chart is triggered by IR sensor giving an output voltage, which is configured in MATLAB as having at least 2.5mV. After the image processing steps are complete, the number of blisters is obtained, depending on which whether the box is a Pass or a Fail is determined. The result of processing is further used to generate a control signals via microcontroller to various field devices and actuators used in the system.

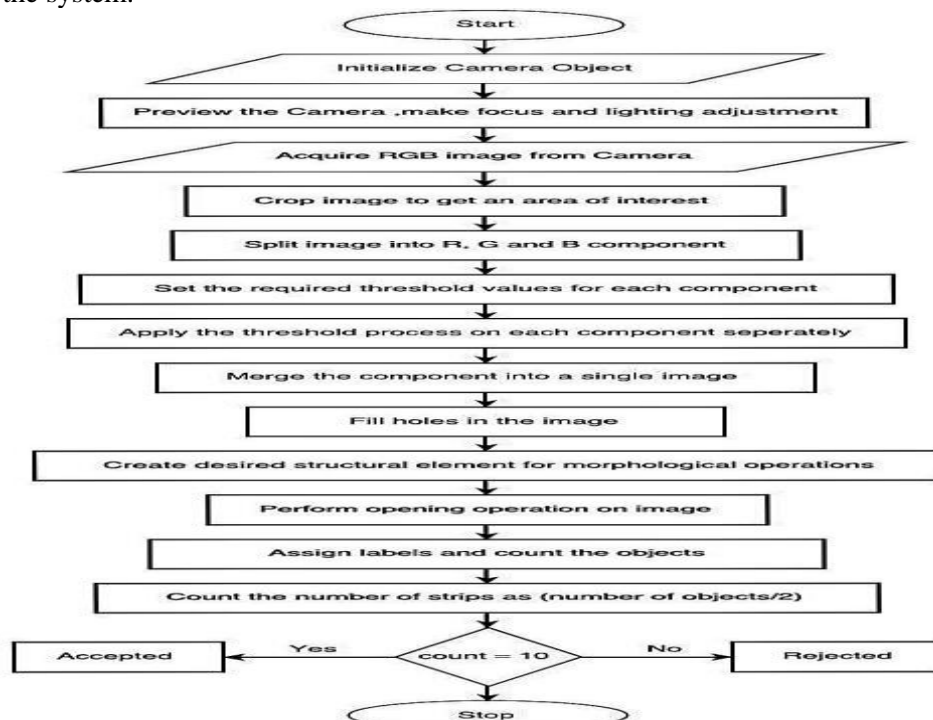

Figure.5. Flowchart showing the image processing steps

Simulation: Tests are conducted based on different number of blisters in the box to verify whether the output matches the experimental conditions. Of these tests, the most significant cases are outlined here. In each of the cases, the main three steps are:

- Splitting the image into its R, G and B components, thresholding and combining into a single image.
- Filling holes, and opening the image to produce a binary image with distinct objects.
- Displaying the final result, with bounding boxes showing each object, and tallying the number of objects

Experiment with 9 blisters in box

	<p>The R, G, B components are extracted from the full color image, and are threshold with the values.</p> <p>The bottom-right image shows the recombined image, which is used for the subsequent steps. 18 tablets are distinctly visible.</p>
	<p>The image is put through the enhancements, and filtering processes. The opening operation widens the gap between two adjacent tablets. Hence counts 18 objects separated by black space.</p>

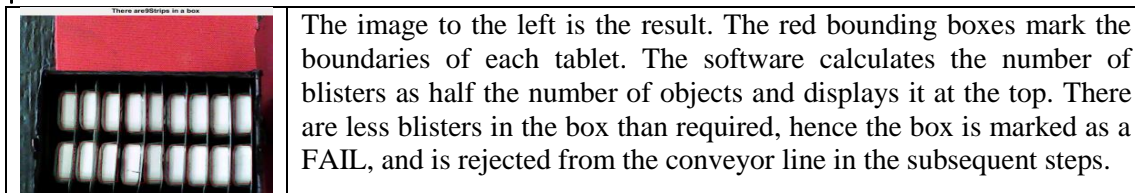

Experiment with 10 blisters in box

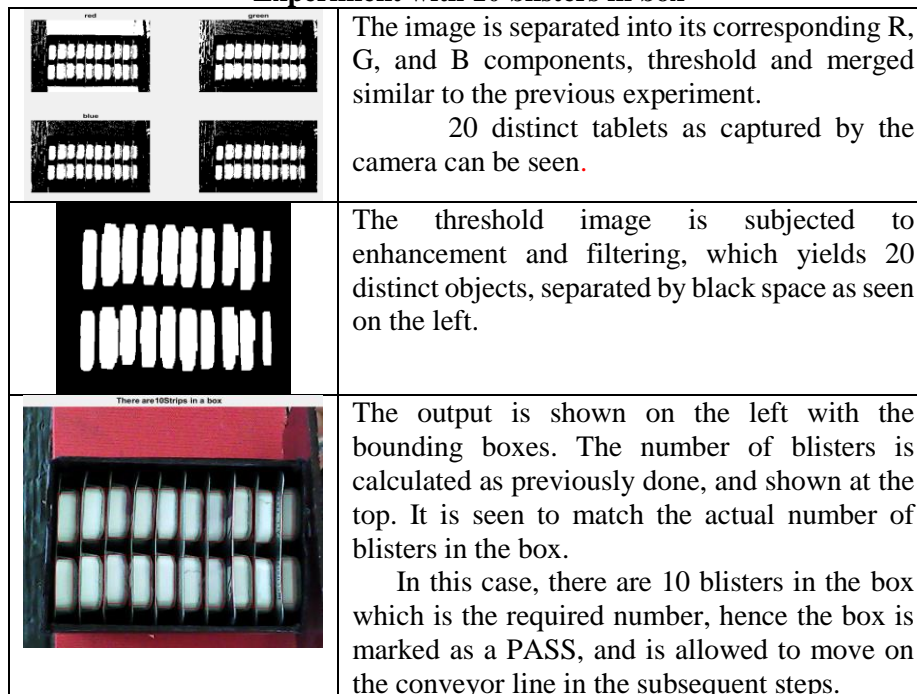

3. RESULTS

The implementation of automatic blister sorting algorithm was done using image processing successfully on a conveyor set up developed as shown in the Figure 3. The testing was done to check the number of blisters in a packet and was tested for 6 and 10 blisters. The system was able to reject the packet with less or more number of blisters than defined. The results were positive for all number of repetitions which proves its robustness. The environment change can have impact on the lighting conditions which should be calibrated for better results.

4. CONCLUSION

The setup used to inspect the number of blisters in a box was found to be effective and is a great improvement over manual inspection methods. The core of this project is based on the concept of image processing which helps in the automation of detection of anomalies using various techniques. The algorithm used for image processing is efficiently established and suitably adjustable for various cases. The method chosen in the process to implement the image processing is morphology operation followed by object detection. This usually gives a more accurate result than template matching because of the pre-processing involved.

REFERENCES

- Abha Sharma, Sugandha Arora, Inspection and Classification of Defects in Pharmaceutical Capsules Using Neural Network, International Journal of Engineering Research and Development, 1 (10), 2012, 41-45.
- Miosso CJ, Bauchspiess A, Fuzzy Inference System Applied to Edge Detection in Digital Images, Proceeding of the Brazilian Conference on Neural Networks, 2001, 481-486.
- Ramya S, Suchitra J, Nadesh R.K, Detection of Broken Pharmaceutical Drugs using Enhanced Feature Extraction Technique, International Journal of Engineering and Technology, 2, 2013, 1407 -1411.
- Shalinee Patel, Pinal Trivedi and Vrundali Gandhi, 2D Basic Shape Detection using Region Properties, International Journal of Engineering & Technology, 2 (5), 2013, 1147-1153.