

A Parallel architecture of Fuzzy tuned PID and PD based Controller for Speed control in BLDC Motor

K. Harshavardhana Reddy¹, Sudha Ramasamy¹, Prabhu Ramanathan^{*}, N.M. Nandhitha²

¹School of Electrical Engineering, VIT University, Vellore, India.

²Department of ETCE, Sathyabama University, Chennai, India

^{*}Corresponding author: E-Mail: ishupa@gmail.com

ABSTRACT

In this article a controller with parallel architecture of Fuzzy tuned PID and PD controller is designed and implemented for speed control of brushless DC motor. The proposed controller has only one fuzzy gain tuner to tune the three gain parameters (k_p , k_i , k_d). A classical PD controller will be placed in parallel to fuzzy tuned PID controller. The proposed controller architecture with merits of the classical PD and fuzzy tuned PID will be a better alternative for controlling the speed of a Brushless motor. The time domain specifications of BLDC motor, obtained using the proposed controller with parallel architecture of fuzzy tuned PID and PD controller are compared with response obtained PI controller and fuzzy tuned PID controller. The controller is tested with variable speed and variable load conditions. The design of proposed controller is very simple and it is effective because very low settling time, it has zero peak overshoot and zero steady state error.

KEY WORDS: Brushless DC Motor, PD controller, PI controller, Fuzzy tuned PID controller, three phase voltage inverter.

1. INTRODUCTION

The BLDC (Brushless DC) Motor is a permanent magnet synchronous motor (PMSM) with trapezoidal Back EMF. The advantages of the BLDC motors are they have high efficiency, better torque characteristics, high power density, no mechanical commutators and easier control. Because of these advantages, the BLDC motors are used in numerous applications like aeronautics, robotics, velocity control system, electrical vehicles, food and chemical industries. The speed control of BLDC motor is a key topic in the field of control theory. The BLDC motor is a multivariable and nonlinear system, so as to control the speed of these BLDC motors is a challenging task in many applications. The tuning conventional Proportional/Proportional Derivative/Proportional Integral/ Proportional Integral Derivative (P/PD/PI/PID) controllers were first proposed by Ziegler-Nichols. By this authors proposed a formula for tuning conventional PI/PD/PID controllers by using transfer function of the system. As the conventional controllers are used in many applications like electrical, chemical and industrial control applications, etc. over a few decades because of their simple design. The disadvantages of conventional PID controllers are they have poor performance when there are load variations.

The windup phenomenon appears in PID controller when the controller output is saturated. To control the windup effect, an anti-windup function is introduced in the PI/PID controllers. The authors in presented an anti-windup strategy for PI controller to control the speed of motors. In this method, when P controller is changes to PI controller, a suitable initial value for the integrator is assumed. This method performs well in different load conditions. The main disadvantage of anti-windup PI controller is that it has larger undershoot and steady state error. In authors proposed an auto tuning of the PI controller to control the speed of a PMSM drives. With this controller, parameter gain is continuous changes with respect to a current trend. To accomplish the disadvantages of PI/PID controller's researchers introduced optimization techniques to obtain optimal gain parameters. In the authors projected an optimal tuning approach of PID controllers using practical swarm optimization (PSO) and Bacterial Forging (BF) optimization algorithms to improve the step response characteristics of BLDC motor. The disadvantages of this method are it has larger overshoot and steady state errors during sudden load disturbances.

To improve the performance in industrial applications the researchers found out that the Fuzzy logic controllers will be more suitable. The advances in artificial intelligent applications like neural networks, fuzzy logic controller, soft computing techniques, etc. are used in speed control of BLDC motors. These techniques give outstanding results. The below literature shows the soft computing techniques to control the speed in motors. In the authors presented a fuzzy logic controller for achieving improved speed performance of a BLDC servo motor drive. In this the authors implemented a fuzzy logic controller in digital form. The presented controller is effective in dealing with uncertainties and parameter variations when compared to normal PID controllers.

In the research article the authors proposed an adaptive fuzzy controller to control the speed of DC motors using state and output feedback. In this neuro fuzzy is developed to approximate the unknown system dynamics. The present controller has to transform the nonlinear control problem into a regulation problem through state or output feedback. In the authors designed an adaptive fuzzy logic controller for the control speed of DC motors based on Field Programmable Gate Array (FPGA).

To get a more accurate response of controllers the researchers optimized some parameters in fuzzy logic controllers. In the authors described an optimized fuzzy logic controller to control the speed of PMSM drive. The fuzzy logic controller is optimized through genetic algorithms. In this the known ledge based membership function is optimized to obtain an optimal fuzzy logic controller. This controller has three closed loops, the first two inner closed loops are current and velocity feedbacks and third outer loop is a genetic algorithm loop which optimizes the rule base and data base.

In the papers the authors describe a fuzzy gain scheduling for PID controllers used in applications of process control. In these types of controllers, the fuzzy rules and reasoning are used to find the controller parameters based on error signal and change in error signal. In the authors described a parallel structure of the fuzzy PID controller. The controller's tuning method is based on gain and phase margins. Using the defined phase and gain margins, weight factors of fuzzy PID controller with respect to plants will be estimated. This controller gives higher controller gains when compared to the conventional PID controller.

In researchers proposed a parallel fuzzy PID controller to achieve better performance of BLDC motors. The architecture of fuzzy PID controller having the three fuzzy sub controllers for three gain parameters k_p , k_i , k_d and then these parameters is added to form complete fuzzy PID controller. This existing controller handles the non-linearity and external disturbances. The demerits of these above stated Fuzzy PID controllers are that it exhibits large steady state error.

In the authors presented a fuzzy proportional derivative controller to control the speed of BLDC motor using the bat optimization algorithm. This controller produces a large overshoot and more oscillations. In the authors projected an adaptive neuro fuzzy controller to control the speed of permanent magnet excitation transverse flux linear motor. This controller has two fuzzy inputs and one fuzzy output. The scaling factors of fuzzy logic controller are trained by artificial neural network.

So in this work a new controller is proposed to improve the settling time, response while load variations and zero steady state errors to achieve better performance.

In this article, a Parallel combination of Fuzzy tuned PID controller and PD controller is proposed to control the speed of the brushless DC motor. The block diagrams of the existing Fuzzy tuned PID controller are shown in Figure.1.

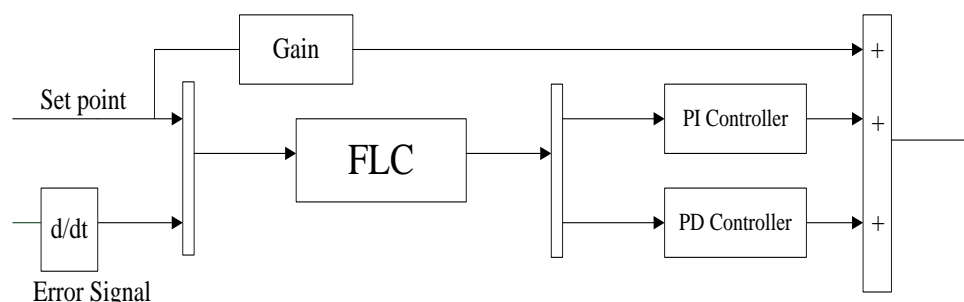

Figure.1. Block diagram of Fuzzy tuned PID controller

Methodology to control the speed of BLDC motor: The merits of the BLDC motor when compared to the DC motor is that it has higher reliability, lower electromagnetic interference (EMI) and lower maintenance costs. The various fields of applications of BLDC Motor are aerospace, domestic, industrial automation, medical, textile industry and digital control machine tools.

Generally the Brushless DC Motor consists of a three stator windings and permanent magnets on the rotor. Brushless DC Motor is stated as the trapezoidal back EMF permanent magnet synchronous motor. The line to line voltage equations are expressed in Equation. (1).

$$\begin{bmatrix} V_{ab} \\ V_{bc} \\ V_{ca} \end{bmatrix} = \begin{bmatrix} R & -R & 0 \\ 0 & R & -R \\ -R & 0 & R \end{bmatrix} \begin{bmatrix} i_a \\ i_b \\ i_c \end{bmatrix} + \begin{bmatrix} L & -L & 0 \\ 0 & L & -L \\ -L & 0 & L \end{bmatrix} \begin{bmatrix} \frac{di_a}{dt} \\ \frac{di_b}{dt} \\ \frac{di_c}{dt} \end{bmatrix} + \begin{bmatrix} e_a - e_b \\ e_b - e_c \\ e_c - e_a \end{bmatrix} \quad (1)$$

Where, V_a, V_b, V_c represents the phase voltage of BLDC Motor in Volts, R represents the resistance of stator Windings in ohms, i_a, i_b, i_c represents phase currents of the motor in amperes, L represents the Self Inductance in Henry, M represents the mutual inductance and e_a, e_b, e_c denotes the trapezoidal back EMF of each phase in volts. P represents the number of poles in the rotor. The electromechanical torque of the BLDC motor is given in equation. (2).

$$T_a = (e_a i_a + e_b i_b + e_c i_c) / w_1; w_1 = \frac{d\theta_r}{dt} \quad (2)$$

The terms w_1, θ_r represents the rotor position, angular velocity (rad/s). The electromagnetic torque is utilized to overcome the opposing torques of inertia and load, it can be expressed as in equation. (3).

$$T_a = T_L + J_n \frac{dw}{dt} + B_n w \quad (3)$$

Then the terms T_L represents load torque (NM/A), J_n is Momentum of Inertia (J or kg.m²), B_n indicates Friction coefficient.

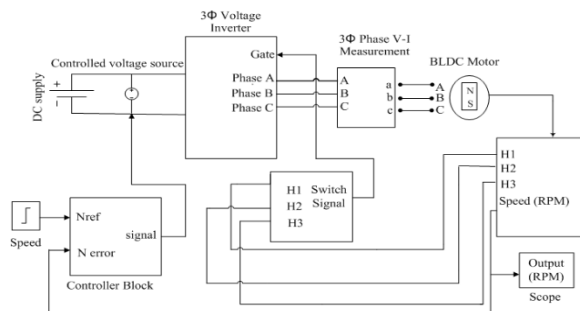

Figure.2. Simulink Model diagram of Speed Control of BLDC Motor

To analyse and verify the performance of the proposed controller architecture, simulations were performed in MATLAB. The basic building block of closed loop control system for this article are BLDC motor, DC power supply, three phase voltage Inverter, three phase V-I Measurement block, controlled voltage source and switching logic circuits. The reference signal speed 1200 rpm is given as input signal and output speed signal of the BLDC Motor is given to the proposed controller as feedback. The controller output is given to controlled voltage source. The switching logic is developed by using three hall signals H₁, H₂, H₃, and this switching logic is given as gating signal to three phase voltage inverter. The output signal of proposed controller is given to the controlled voltage source and three phase inverter controls the speed of the BLDC Motor. The Figure.2, shows the Simulink diagram for speed control of BLDC Motor.

Fuzzy tuned PID Controller: The fuzzy systems are universal approximations. Fuzzy systems are used in situations involving having high complex systems, and the system whose behaviour is not clean. Error and rate of change in error are the two inputs for the fuzzy interface system. The block diagram of the fuzzy inference system is shown in Figure.3. Both inputs and outputs have 7 triangular membership functions. The input range for both input and output is between [-0.5 to 0.5]. The distribution of the membership functions has even functions, negative big, negative medium, negative small, zero, positive small, positive medium and positive big. The distribution of the membership functions it shown in the Figure.4.

The defuzzification of these fuzzy sets is given by the centroid method. The centroid method is also called as the centre of area or the centre of gravity method Forty nine rules are taken for tuning the fuzzy tuned PID controller to control the BLDC motor.

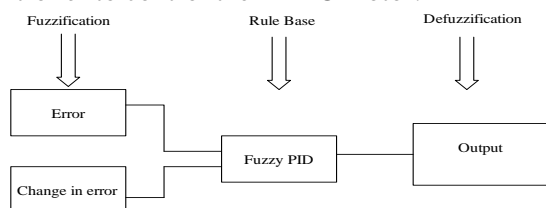

Figure.3. Madmani Fuzzy interface system

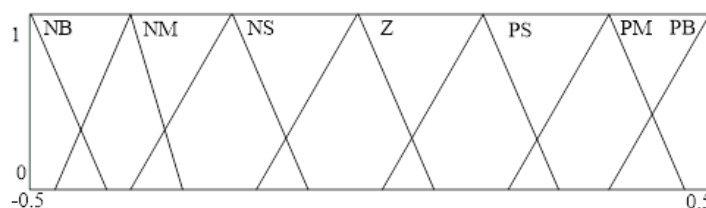

Figure.4. Membership functions of inputs and outputs for proposed controller

PD Controller: The Conventional PD controller has simple structure with combination of proportional and derivative controllers. The main advantage of the PD controller is, it will decrease the overshoot and settling time. The Fuzzy tuned PID controller is mostly used in speed control of BLDC motor. The fuzzy tuned PID is, it has large settling time. To overcome this issue, a conventional PD controller is configured parallel to the Fuzzy tuned PID controller. It is shown that this technique has, decreased settling time, compared the other controllers. The below Figure.5, shows the block diagram of proposed Controller.

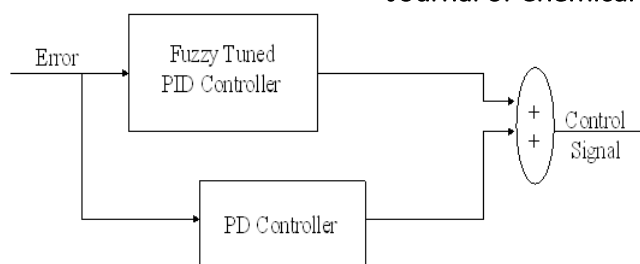

Figure.5. Block diagram of proposed controller

3. RESULTS AND DISCUSSIONS

Speed response of the BLDC motor is analysed under the constant load, varying load conditions. The control system parameters such as rise time, peak time, settling time, steady state error, peak overshoot, integral absolute error, are used to compare the speed response of a proposed controller with fuzzy PID controller and PI controller. The specifications of the BLDC motor are shown in Table.1

Table.1. Specifications of BLDC Motor

| Specifications | Value |
|---|---------|
| Rated Voltage (V) | 500 |
| Rated Current (A) | 8 |
| Rated Speed (RPM) | 1200 |
| Stator phase Resistance, R (Ω) | 14.5 |
| Stator phase Inductance, L (H) | 0.0025 |
| Flux Linkage Established in Magnets (V.s) | 0.010 |
| Voltage Constant (V/krpm) | 77.4 |
| Torque Constant (Nm/A) | 0.74 |
| Back EMF flat Area (Degrees) | 120 |
| Moment of Inertia J (kg/m^2) | 0.00013 |
| Friction factor (N m/(rad/s)) | 0.0001 |
| Pole Pairs | 4 |

Speed Response with constant load 25 Nm: The simulation results for speed control of Brushless DC motor under constant load condition is shown in fig.6. The set point of the speed is 1200 RPM. The time domain specifications of the output response are shown in Table.2. The steady state error of PI controller and fuzzy tuned PID controller is 0 and 0.2 respectively. The steady state error of parallel architecture of fuzzy tuned PID and PD controller is zero.

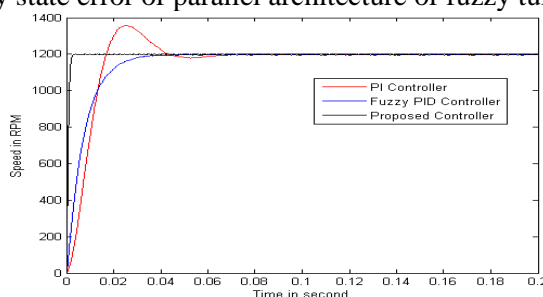

Figure.6. Speed response for different controllers at constant load 25 Nm

The settling time for PI controller and fuzzy tuned PID controller is 0.07s and 0.052s. The settling time for proposed controller is 0.005s.

Table.2. Comparison of output response parameters for constant load 25 Nm condition

| Type of Controller | Control system Parameters | | | | | | |
|---------------------|------------------------------|------------------------------|------------------|--------------------|----------------------------------|--------------------------|--------|
| | Rise Time (t_r) (Second) | Peak Time (t_p) (Second) | Peak Value (RPM) | Peak Overshoot (%) | Settling Time (t_s) (Second) | Steady State Error (RPM) | IAE |
| PI | 0.015 | 0.025 | 1345 | 12 | 0.07 | - | 8.127 |
| Fuzzy tuned PID | 0.016 | - | - | - | 0.052 | 0.2 | 5.8521 |
| Proposed Controller | 0.002 | - | - | - | 0.005 | - | 0.86 |

The Integral absolute error (IAE) for PI controller, fuzzy tuned PID controller and proposed parallel architecture of fuzzy tuned PID and PD controllers is 8.127, 5.8521 and 0.86 respectively. By observing the time domain specifications the proposed controller it can be said that gives the fuzzy PID plus PD controller gives the better response for speed control of BLDC motor.

Speed Response with varying Load 1 Nm to 25Nm: The simulation results for speed control of Brushless DC motor under varying load condition are shown in fig.7. The load is varied from 1Nm to 25 Nm torque. The time domain specifications of the output response are as shown in Table.3. The steady state error of PI controller and fuzzy tuned PID controller is 0 and 0.7 respectively. The steady state error of proposed parallel architecture fuzzy tuned PID and PD controller is 0.

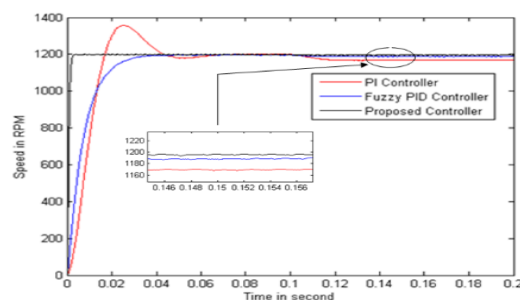

Figure.7. Speed response for different controllers at varying load 1 Nm to 25 Nm

The recovery time of PI controller and fuzzy tuned PID controller is 0.22s and 0.19s. The recovery time for proposed controller is 0.153s.

Table.3. Comparison of output response parameters for varying load (1 Nm to 25 Nm) condition

| Type of Controller | Control system Parameters | | | |
|---------------------|---------------------------|------------------------|--------------------|-----------|
| | Peak Overshoot (%) | Recovery Time (Second) | Steady state Error | IAE Error |
| PI | 4.1 | 0.22 | - | 12.6 |
| Fuzzy tuned PID | - | 0.19 | 0.5 | 9.085 |
| Proposed Controller | - | 0.153 | - | 1.03 |

The Integral absolute error (IAE) for PI controller, fuzzy tuned PID controller and parallel architecture fuzzy tuned PID and PD controller is 12.6, 9.085 and 1.03 respectively. The peak overshoot for PI controller, fuzzy tuned PID controller and parallel with fuzzy tuned PID and PD controller is 4.1, 0 and 0 respectively. By observing the time domain specifications the proposed controller gives the better response for speed control of BLDC motor.

Speed Tracking Response for Proposed Controller: The speed tracking response for the controllers is shown in fig.8. It shows the proposed controller has faster response than PI controller and fuzzy PID controllers at different set points of reference speed. The proposed controller has taken very lesser time to achieve the set point speed.

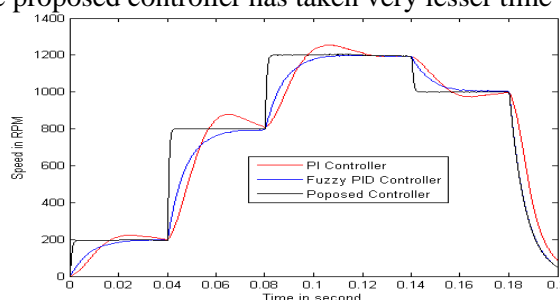

Figure.8. Controllers response at speed tracking set points

4. CONCLUSIONS

The proposed controller has an advantage of simple design as it is combination of fuzzy and conventional controllers. To control the speed of brushless DC motors the proposed parallel architecture of fuzzy PID and PD controller gives better performance than fuzzy tuned PID controller and PI controller. The proposed controller settles very faster with negligible steady state error, better rise time and very low integral absolute error compared to previous controllers.

REFERENCES

Choi, Jong-Woo, and Sang-Cheol Lee, Antiwindup strategy for PI-type speed controller, Industrial Electronics, IEEE Transactions on, 56 (6), 2009, 2039-2046.

Gupta R.A, Rajesh Kumar, and Ajay Kumar Bansal, Artificial intelligence applications in Permanent Magnet Brushless DC motor drives, Artificial Intelligence Review, 33 (3), 2010, 175-186.

Hasanien, Hany M, Muyeen S.M, and Junji Tamura, Speed control of permanent magnet excitation transverse flux linear motor by using adaptive neuro-fuzzy controller, *Energy Conversion and Management* 51 (12), 2010, 2762-2768.

Ibrahim H.E.A, Hassan F.N and Anas O, Shomer, Optimal PID control of a brushless DC motor using PSO and BF techniques, *Ain Shams Engineering Journal*, 5 (2), 2014, 391-398.

Kandiban R and Arulmozhiyal R, Speed control of BLDC motor using adaptive fuzzy PID controller, *Procedia Engineering*, 38, 2012, 306-313.

Lai, Yen-Shin, and Yong-Kai Lin, A unified approach to zero-crossing point detection of back EMF for brushless DC motor drives without current and hall sensors, *Power Electronics, IEEE Transactions on*, 26 (6), 2011, 1704-1713.

Ma, Wuning, Cheng Xu, and Fan Yang, An Auto-Tuning PI Controller for the Speed Control of a Permanent Magnet Synchronous Motor Drive, *Practical Applications of Intelligent Systems*, Springer Berlin Heidelberg, 2011, 141-146.

Ozturk, Nihat and Emre Çelik, Speed control of permanent magnet synchronous motors using fuzzy controller based on genetic algorithms, *International Journal of Electrical Power & Energy Systems*, 43 (1), 2012, 889-898.

Ozturk, Salih Baris, and Hamid A. Toliyat, Direct torque and indirect flux control of brushless DC motor, *Mechatronics, IEEE/ASME Transactions on*, 16 (2), 2011, 351-360.

Pillay, Pragasen, and Ramu Krishnan, Modeling, simulation, and analysis of permanent-magnet motor drives I, The permanent-magnet synchronous motor drive, *Industry Applications, IEEE Transactions on*, 25 (2), 1989, 265-273.

Premkumar K and Manikandan B.V, Bat algorithm optimized fuzzy PD based speed controller for brushless direct current motor, *Engineering Science and Technology*, 2015.

Ramadan E.A, El-Bardini M and Fkirin M.A, Design and FPGA-implementation of an improved adaptive fuzzy logic controller for DC motor speed control, *Ain Shams Engineering Journal*, 5 (3), 2014, 803-816.

Rigatos, Gerasimos G, Adaptive fuzzy control of DC motors using state and output feedback, *Electric Power Systems Research*, 79 (11), 2009, 1579-1592.

Rubaii, Ahmed J, Castro-Sitiriche, and Abdul R, Ofoli, Design and implementation of parallel fuzzy PID controller for high-performance brushless motor drives, an integrated environment for rapid control prototyping, *Industry Applications, IEEE Transactions on*, 44 (4), 2008, 1090-1098.

Shanmugasundram R, Muhammad Zakariah K and Narri Yadaiah, Implementation and performance analysis of digital controllers for brushless DC motor drives, *Mechatronics, IEEE/ASME Transactions on*, 19 (1), 2014, 213-224.

Xu, Jian-Xin, Chang-Chieh Hang, and Chen Liu, Parallel structure and tuning of a fuzzy PID controller, *Automatica*, 36 (5), 2000, 673-684.

Zhen-Yu Zhao, Tomizuka M, Isaka S, Fuzzy gain scheduling of PID controllers, in *Systems, Man and Cybernetics*, *IEEE Transactions on*, 23 (5), 1993, 1392-1398.

Ziegler, John G, and Nathaniel B, Nichols, Optimum settings for automatic controllers, *trans ASME*, 64 (11), 1942.