

PADDY THRESHER AND PERFORMANCE ANALYSIS UNDER VARIOUS CONDITIONS OF PADDY STRAW

Dr. A K Murthy

Professor and Dean, Department of Mechanical, AMCEC, Bangalore, India

Santhosh Kumar B K

Assistant Professor, Department of Mechanical, AMCEC, Bangalore, India

Prashanth P, Pavan Kumar P, Nitesh Kumar BM, Rakshan Rai

Student, Department of Mechanical, AMCEC, Bangalore, India

ABSTRACT

Paddy is the most vital and extensively grown up food crop within the World. It's the staple food of over sixty percent of the globe population; Thresher may be a rice seed separation tool. Threshing is a key part of agriculture that involves removing the seeds or grain from plants stalk. Paddy separation activity undertaken by farmer's mistreatment in two ways, one method is manual beating of paddy on picket platform and by mistreatment operated by hand paddy thresher that requires great deal of human labour. So as to mechanize this method, a machine is meant with separation, major dust removal and fine dirt removal chambers and tested. So a thresher with two rollers at the entry of the feeding system whereby one acts as driver and other remains writing paper guides the paddy into separation cylinder. The threshing operation are achieved by motion of a cylinder, the grains constitute the improvement unit that consists of a sieve that undergoes a reciprocating motion.[1] The machine is straight forward, less large and comfy use. The winning development of this machine is predicted to cut back the human labour concerned in separation at the reasonable price and conjointly reduces the time used for separation operation on little farms.

Keywords: Farm Machinery, Power Engineering, Paddy Thresher, Paddy Straw, Farmer.

Cite this Article: Dr. A K Murthy, Santhosh Kumar B K, Prashanth P, Pavan Kumar P, Nitesh Kumar BM and Rakshan Rai, Paddy Thresher and Performance Analysis Under Various Conditions of Paddy Straw, *International Journal of Advanced Research in Engineering and Technology*, 10(3), 2019, pp 36-46.

<http://www.iaeme.com/ijaret/issues.asp?JType=IJARET&VType=10&IType=3>

1. INTRODUCTION

Paddy is that the most significant and extensively fully grown food crop within the World. Thresher could be a rice seed separation tool. Separation could be a key a part of agriculture that involves removing the seeds or grain from plants stalk Paddy separation activity undertaken by farmer's victimization 2 strategies. One technique is manual beating of paddy on picket platform and by victimization operated by hand paddy thresher which needs great deal of human labor. So as to mechanize this method, a machine is intended with separation, major mud removal and fine mud removal chambers and tested. Thus a thresher with 2 rollers at the entry of the feeding system whereby one acts as driver and different remains letter paper guides the paddy into separation cylinder. The separation operation are going to be achieved by move motion of a cylinder, the grains constitute the cleansing unit that consists of a sieve that undergoes a reciprocal motion. The machine is straightforward, less large and comfy use. The undefeated development of this machine is predicted to scale back the human labour concerned in separation at a reasonable price and additionally reduces the time used for separation operation on tiny farms separation and dirt removal is an integral a part of postharvest activities for cereal and legume crops. In several developing countries, separation and dirt separation is distributed manually by farmers that cause quality of paddy rice and grain loss. Once the rice production will increase, consequently the manual separation and dirt separation becomes arduous.

2. METHODOLOGY

Paddy separation from the straw is completed by some external wave force or by some impact force with the air of our machine "Paddy Thresher", methodology of paddy separation is formed terribly simple over the standard method. Once the gather of paddy Crops they're to be stacked in an exceedingly specific space with regards to the machine. The Machine's impacting drum is formed to rotate at low speed. A bunch of paddy crops are control over the rotating drum, which can undergoes impact force and wave force that makes the paddy to separate or cut loose the straw. Since the impacting force won't affects the paddy crop to chop down. Separated paddy is formed to go over a vibratory sieve. This vibratory sieve takes vital half because it separates the foremost mud particles like straws; grasses etc....from the sieve, paddy falls right down to a paddy assembling receptacle that takes the foremost mud removed paddy the specified paddies are collected from the machine outlet port at the lower surface.

The Paddy thresher machine constitutes the most functions as separation of paddy, major mud removal and therefore the removal fine mud particles of these functions are done at a time in an exceedingly single machine. So as to get high potency, all the elements of the machine are to be worked in correct manner.



Figure 1

3. THRESHING ANALYSIS

3.1. Spike Tooth Type Cylinder

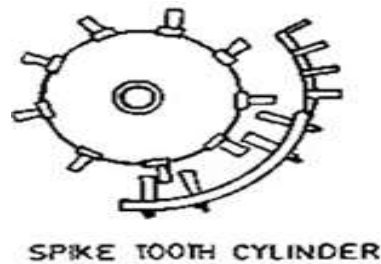

Figure 2

In this kind of separation drum, there's a hollow cylinder, created out of MS flat. Over to its entire edge, variety of spikes/pegs of sq. /round bars or flat iron items square measure welded or barred. In most of threshers, spherical peg with adjustable length square measure used. These spikes square measure staggered on the edge of the drum for uniform separation. The crop is fed alongside the direction of motion of the rotating drum. The spike tooth cylinders measure accessible in numerous sizes. A spike tooth cylinder with spikes of flat front and efficient back has lower energy consumption.

3.3. Rasp Bar Type Cylinder



Figure 3

In this sort of cylinder, there area unit slotted plates, that area unit fitted over to the cylinder rings, in such the way that the direction of slot of 1 plate is opposite to a different plate. This kind of cylinder is usually utilized in threshers [2]

3.4. Hammer Mill Type Cylinder



Figure 4

It uses beaters to try and do the desired job of separation. The form of this kind of cylinder is completely different from the above-discussed cylinder. The beaters square measure product of flat iron items and square measure mounted radically on the axis of rotation. Usually feeding chutes square measure used with hammer mill sort separation cylinder.[2]The cut crop is fed perpendicular to the direction of motion of rotating beaters. This kind of thresher needs a lot of power as compared to spike tooth kind of thresher

4. SIEVING MECHANISM

Sieve analysis is a method of determining the particle size distribution of a material. The process separates fine particles from more course particles by passing the material through a number of sieves of different mesh sizes.[6]

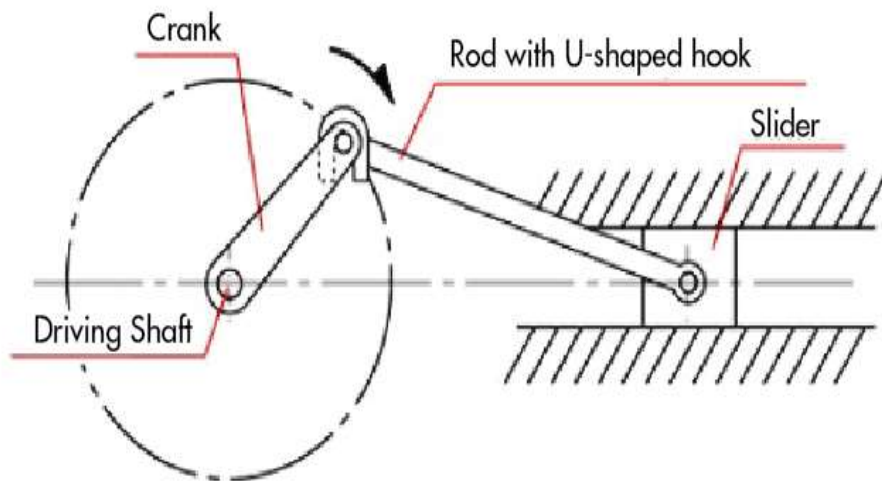

Figure 5

4.1. Design

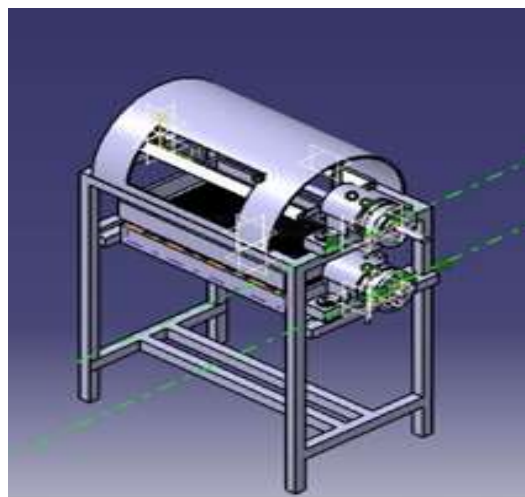

Figure 6

5. DESIGN CALCULATIONS

Shaft: It is a rotating element, usually circular in cross-section, which is used to transmit power from one part to another.

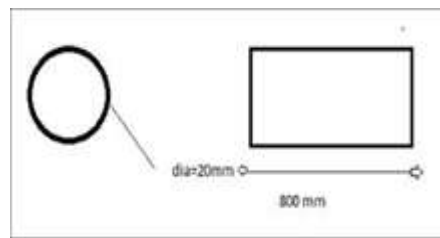

Figure 7

Material	=	MILD STEEL
Density	=	7.85g/M3
Volume	=	$\pi*r^2*h$
	=	$\pi*(2/2)^2*80$
	=	251.32cm ³
Mass	=	density*volume
	=	7.85*251.32
	=	1972.92gram
	=	1.972gram
	=	19.35 N

Blade: A flat thin part r section, especially one that makes contact to perform desired action

Material	=	MILD STEEL
Density	=	7.86 g/cm ³
Volume	=	$l*w*h$
Mass	=	density*volume
	=	7.85*96
	=	753.6 g
Number of blades used	=	4
Total mass	=	4*753.6
	=	3014.9 g
	=	3.0149 Kg
	=	29.567 N

Cover

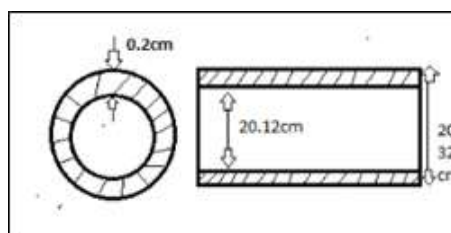

Figure 8

MATERIAL = MILD STEEL
 Density = 7.85 g/cm³
 = 16*0.1*60
 = 96 cm³
 Volume = $\pi \cdot h (r_1^2 - r_2^2)$
 Volume = $\pi \cdot h (20.32^2 - 20.12^2)$
 = 1575.37 cm³
 Mass = 1575.37*7.85
 = 12366.65 g
 = 121.25 N

Paddy

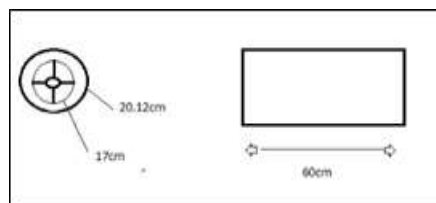

Figure 9

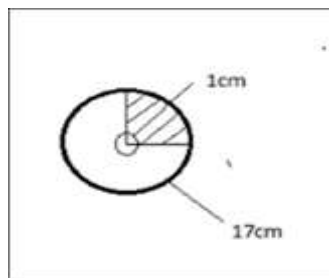

Figure 10

Density of paddy = 1.452 g/ml
 Volume of part 1 = $\pi \cdot h \cdot (r_1^2 - r_2^2)$
 = 21830.5 cm³
 Volume of part 2 = volume of hollow cylinder / 4
 = 54286.72 / 4
 = 13571.68 cm³
 Total = 53286.72 + 21830.5
 = 76117.22 cm³
 Mass = density * volume
 = 1.452 * 76117.22
 = 110522.20 g
 = 110.52 kg
 = 1084.22 N
 Total Force = 1254.387 N
 Power P = $\pi \cdot d \cdot F \cdot N / (60 \cdot 1000)$ = $\pi \cdot 0.2 \cdot 1254.387 \cdot 1400 / (60 \cdot 1000)$

$$= 1.8 \text{ kW}$$

$$1 \text{ HP} = 0.74 \text{ KW}$$

$$1.8 \text{ KW} = 1.4 \text{ HP}$$

Fabrication



Figure 11



Figure 12

6. PADDY ANALYSIS

6.1. Dryness

When paddy is harvested, it'll contain up to 25% wetness. High wetness level throughout storage will cause grain discoloration, encourage development of molds, and increase the chance of attack from pests. It also can decrease the germination rate of the rice seed. It is vital to dry paddy grain as before long as potential once harvesting—[5] ideally inside twenty four hours. Delays in drying, incomplete drying or ineffective drying can cut back grain quality and end in losses.

Table 1

STORAGE PERIOD	REQUIRED MC FOR SAFE STORAGE	POTENTIAL DAMAGE
Weeks to few month	14% or less	Moulds, respiration loss insect damage, moisture adsorption
8–12 months	13% or less	insect damage
storage of farmer's seeds	12% or less	loss of germination
<1 year	9% or less	loss of germination

Paddy drying methods include traditional and mechanical systems with varying technological complexity and capacities for either farm or commercial level.

- Sun drying
- Mat drying
- Pavement drying
- Batch dryer
- Re-circulating batch dryer



Figure 13

6.2. Moisture Content

Moisture content is a vital amount for agriculture product, particularly in paddy. In essence, the wet content is measured by a measurement methodology that may be a direct methodology. The menstruation results have a typical uncertainty of 1.23% of wet content in range of 14% to 20%

Equation to find moisture content [9]

$$MC = [(m_o - m) / m_o] * 100$$

Where MC - Moisture Content

m_o - mass of paddy before drying

m - Mass of paddy after drying

Table 2

Operation	Desired moisture content	Primary losses
Harvesting	20–25%	shattering if grain is too dry unfilled and many green grains if too wet
Threshing	20–25% for mechanical threshing less than 20% for hand threshing	incomplete threshing, grain damage, and cracking/breakage
Drying	final moisture content is 14% or lower	spoilage, fungal damage, discoloration
Storage	less than 14% for grain storage than 12% for seed storage less than 9% for long term seed preservation	fungal, insect, and rat damage loss of vigor loss of vigor
Milling	13–14%	grain cracking and breakage over milling

7. MEASURING PHYSICAL QUALITY OF PADDY:[8]

7.1. Crack Detection

Using the paddy crack detector, count the number of cracked grains in a 100-grain sample; then compute the % of cracked grains using the equation:

$$\text{Cracked grains (\%)} = \frac{\text{Cracked grains (no.)}}{100 \text{ grains}} \times 100$$

7.2. Grain Dimensions

Using the Vernier caliper or photographic enlarger, collect 20 paddy samples at random from each replicate and measure the dimensions to obtain the average length and width of the paddy grains. To obtain the paddy shape, the following equation will be used.

$$\text{Length to width ration (L/W)} = \frac{\text{Average paddy length (mm)}}{\text{Average paddy width (mm)}}$$

Paddy will be classified based on standards set by the International Organization for Standardization (ISO) for paddy.

7.3. Immature Grains

- Select a 25-g grain sample.
- Select, segregate, and weigh the immature grains in the sample
- Calculate the percentage of immature grains in the sample using the formula:

$$\text{Immature grains (\%)} = \frac{\text{Weight of immature grains}}{\text{Total weight of samples}} \times 100$$

7.4. Dockage

- Remove light foreign matter, stones, weed, and seeds from a 100-g sample.
- Obtain the total weight. Then compute dockage percentage as follows:

$$\text{Dockage (\%)} = \frac{\text{Weight of dockage}}{\text{Total weight of sample}} \times 100$$

7.5. 1000-Seed Weight

- Count and weigh 1,000 grains (paddy).

8. USE OF STRAWS AFTER EXTRACTION

8.1. Chemical Analysis of Rice Straw

The chemical analysis of straw obtained from the rice crop grown under well managed conditions. The large amount of Nitrogen (N), potassium (K), silicon (Si) is present in the straw is at once evident. That the potassium requirement for rice could be provided by straw it instead of by imported muriatic of potash is also evident.

8.2. Burning of Rice Straws

The Loss of nutrients by burning straws may result from conversion into volatile products at elevated temperature and also from the upward movement of small particles of burnt and semi-burnt straw aided by wind. It was found that burning resulted in a 93% loss of N and 20% loss of K from the amounts originally present in straw.

8.3. Rice Straw Compost

Addition of rice straw compost will eliminate most of the problems arising from direct application of straws. Compost can be added without causing problems associated with toxic products produced by decomposing straw and with nitrogen immobilization.

8.4. Rice Straw Ash

Ash results in large loss of nitrogen and a small loss of potassium. Burning straw is indeed wasteful, but burning and addition of ash seem to be a less troublesome way of putting straw back to a rice crop under field condition.

8.5. Paddy Size



Figure 14

The paddy plant can grow to 1–1.8 m (3.3–5.9 ft) tall, occasionally more depending on the variety and soil fertility. It has long, slender leaves 50–100 cm (20–39 in) long and 2–2.5 cm (0.79–0.98 in) broad. The grain size varies 5–12 mm (0.20–0.47 in) long and 2–3 mm (0.079–0.118 in) thick.

8.6. Required Temperature

It demands temperature of around 25° Celsius and above and rainfall of more than 100 cm. Paddy requires a moderate cool climate with moderate rain. In India, it is grown in winter. It needs temperature 10° C to 15° C for its cultivation. It thrives well in an average temperature of 16° C. Warm and sunny weather is essential at the time of ripening. Paddy requires a rainfall of 50 cm to 100 cm during the growing season. Too much rain is injurious to the plant. On irrigated lands, a rainfall of 40 cm to 50 cm is sufficient. Light rainfall and cloudiness before the grain ripens increase the productivity.

8.7. Density of Paddy

Paddy the density around 1.182 g/ml for round varieties and around 1.224 g/ml for others. Bulk density varied appreciably (0.563-0.642 g/ml), and so did porosity (46-54% in paddy).[5]

9. APPLICATION

- Thresher is a paddy seed threshing tool. Threshing is a key part of agriculture that involves removing the seeds or grain from plants stalk.
- Manually operated paddy thresher requires large amount of human labour. In order to mechanize this process, a machine is designed with threshing, major dust removal and fine dust removal chambers.
- The proposed designed thresher with two rollers at the entry of the feeding system wherein one acts as driver and other remains stationery guides the paddy into threshing cylinder.
- The threshing operation will be achieved by rotational motion of a cylinder; the grains collected in a sieve that undergoes a reciprocating motion and clean up the grains.
- The machine is simple, less bulky and comfortable use.
- The successful development of this machine is expected to reduce the human labour involved in threshing at an affordable cost and also reduces the time used for threshing operation on small farms

REFERENCES

- [1] Dash, S.K. and D.K Das, 1989. Development of a Power-Operated Paddy Thresher. *Mechanization in Asia, Africa and Latin America*. 20(3): 37 – 39.
- [2] Balaji Digamma Gandhi (2015) ‘Performance Evaluation of High Capacity Engine Operated Paddy Thresher’, *Journal of Materials and Design* Vol. 32, pp.1677–1683
- [3] Arun Sarjerao Waghmode (2012) ‘Performance Evaluation of Flow through Paddy Thresher’, (Farm Machinery and Power Engineering). JNKVV. Thesis <http://krishikosh.egranth.ac.in/handle/1/5810018457>
- [4] Yaovi Ouézou Azouma (2009) ‘Design of Throw in Type Paddy Thresher for Small Scale Farmers’ *Indian Journal of Science and Technology* Vol. 2, no.9
- [5] Manish Ahuja (2016) ‘Studies on Axial Flow Paddy Thresher Equipped with Modified Mechanical Feeding Systems. L2014AE176M Thesis.
- [6] Akshay R Nandheshwarb, Hitesh Kirmani, Mukesh Desai (2013) ‘Design and Fabrication of Solar Operated Paddy Thresher, vol. 6 Report.
- [7] Sims GB and Kienzle J (2006) *Farm Power and Mechanization for Small Farms in Sub-Saharan Africa*. FAO, pp: 5-10.
- [8] <http://www.knowledgebank.irri.org/step-by-step-production/postharvest/drying#traditional-drying-systems>
- [9] <http://www.knowledgebank.irri.org/step-by-step-production/postharvest/drying#guidelines-on-proper-drying>
- [10] Abdul Rivai Suleman, The Modeling of Slope Erosion Rate by Using Paddy Straw Fibers as Cover for Land Surface, *International Journal of Civil Engineering and Technology (IJCIET)*, 6(1), 2015, pp 136-146