



An Overview on Latest Trend of Face Milling Operation

Niranjan Kumar Naulakha, Dipesh Thapa, Sai Kiran Reddy B, N Karthik

Department of Mechanical Engineering, School of Engineering and Technology, Jain University,
Bengaluru, Karnataka, India

ABSTRACT

Milling is one of the widely used methods to remove material from the surface of a job. It employs a milling tool which has multiple number of cutting points and is rotated over the work so as to remove the material. Face Milling, on the other hand, is one of the types of milling process in which the surface from which the material has to be removed is placed perpendicular to the cutter axis. Thus, it is very important to know about the life of the tool as it determines the surface finish of the work. Longer the tool life better is the overall output. Therefore, by selecting different parameters such as process parameter, geometry parameter and machining parameter properly, the life of the tool can be improved.

Keywords: Milling Process, Tool Life, Parameters, Response Surface Methodology (RSM), Optimization.

I. INTRODUCTION

a) Milling Machine:

Due to very high accuracy and the process being very efficient, milling machine is widely used in most of the machining operations. Indexing head present in the milling machine helps to provide exact rotation of the work and therefore, make it suitable for numerous purposes. Presence of as many number of teeth as possible aids in better and faster metal removal and reduces the machining time and along with that several works can be machined at the same time. The versatility factor that milling machine possess is not exhibited by any other machine and thus makes it used more as compared to other machines. Along with all these features, production rate is considerably higher with achieving close dimensions. This is because of which machines like shaper, planes, etc.

have been replaced by milling machines. Milling machine provides working on all types of surfaces because of its independent cutter and being smaller in size. Hence, it is very suitable for both limited and mass production. When talking about face milling, as mentioned, the cutter is rotated with its axis being perpendicular to the work. A multi-tooth cutter with inserts in each teeth is used for removing metals at high rate. It comprises of a large-diameter cutter body usually made up of single stock with number of slots machined for the inserts. The inserts are fasted mechanically depending on the work for which it is to be employed.

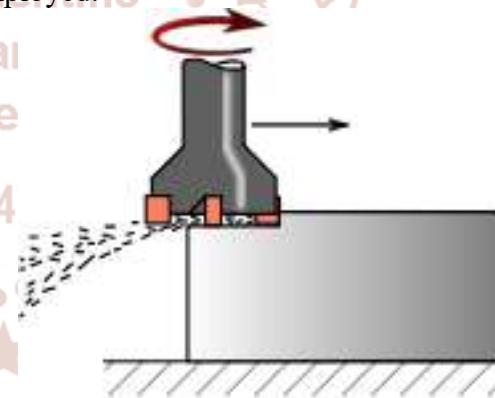

Figure 1: Face Milling



Figure 2: Face Milling Cutter

b) Tool Life

In general, tool life is defined as life of cutting edge of the tool which is usually expressed in time. This is usually the duration of time when the tool is first used for cutting to the time when it wears out and fails to do its work. Cutting edge of the tool gets wear out as it is used for long period of time. The time till which tool works effectively in order to remove the material is called its life. The cutting edge loses its sharpness and it needs to be re-sharpened after regular interval so that it works efficiently. Tool life can also defined as the period when tool is used before it is sharpened. In order to find the tool life corresponding to the cutting speed, Taylor's equation can be used which is given by:

$$VT^n=C$$

Where V is the cutting speed, T is the tool life in minutes and C and n are constants.

The life of the tool is dependent on various parameters and the wearing of the cutting edge can be controlled by controlling those parameters. The parameters are machining, geometric and process parameters. These parameters again depends on different factors like machining parameters include cutting speed, feed rate, depth of cut, etc. Similarly, geometric parameters include tool geometry and process parameters include coolant, Rigidity of machine, work piece material, etc. Therefore, tool life of a cutter depends on all these parameters independently and selecting each of them suitably will increase the overall life of the tool.

II. Literature Survey

1. The research work by S NizamSadiq explains about the role of titanium aluminum nitrite on OHNS materials give good surface finish and tool life with least cost. In this particular experiment of face milling operation of OHNS steel plates with various process parameters such as spindle speed, feed rate and the depth of cut to find optimal machining conditions of minimum surface roughness. [1]
2. The work by Nitin B. Katrodica enlightenment us about the surface roughness a parameter which depends on feed rate (f) like, depth of cut (s), spindle speed, cutting path followed by tool. The aim of the current work is to find effect of cutter paths used in milling operation on surface roughness. The types of cutting path are 1 directional, back and forth and spiral are

considered as cutter path methods. These methods influence the surface finish of work pieces. [2]

3. The motivation of the research by Kannan S. is to investigate the effect of tool nose radius under various cutting conditions and their influence on tool life, surface roughness. Tool nose radius influences on tool life and surface finish. Experiments were performed on grey cast iron. It was observed that change in cutting feed leads to change in cutting temperature, so the cutting speed must influence the tool wear rate. Different parameters effect tool life and surface roughness in machining of various materials. From this work it is clear that to enhance productivity in terms of tool life, surface finish with different cutting parameters, tool materials and tool geometry. [3]
4. The work by Prasanna P Kulkarni mainly explains the about the parameter influence on metal removal rate and surface toughness in aluminium. The right choice of milling parameters such as spindle speed, feed rate and depth of cut are crucial to improve productivity and part quality. This particular work throws knowledge on relationships between input and response variables for improving face milling activity. The methodology called "Response surface" is used for making the relationship between independent and dependent variables. Summarizing the whole, it is important to select the best parameter available for manufacturing industries to ensure better productivity and product quality through a scientific approach. [4]
5. In this work performed by N.S. Pohokar machining parameters, cutting speed, feed, depth of cut, and rake angle are considered. Using a calculator created through MATLAB programming tool life is estimated. Methods such as Taguchi and ANOVA are applied for design of experiment and to determine optimum values of the parameters selected. A VMC machine is used to carry out the trials. Tool life is estimated by flank wear and face wear. The obtained results are compared and optimum combination of parameters are suggested and value of tool life for the combination is estimated. Therefore tool geometry of milling tool is designed for rough milling operation by increasing rake angle. [5]

III. OPTIMIZATION

In order to achieve optimized output, RSM (Response Surface Methodology) would be employed. In this different mathematical and statistical techniques are collected so that empirical model can be built. Once

the design is carefully done then the objective would be to optimize the output corresponding to the independent inputs. Then the several experiments are performed such that in each experiment certain input parameter is varied and its corresponding output is evaluated to note the change. Thus, the main objective of the experiment would be to select the best out of each parameter. Response Surface Methodology is employed for making the analyzing method cheaper and the numerical noise associated to it.

IV. PROBLEM STATEMENT

As mentioned earlier, the life of the tool is dependent upon different parameters like machining, geometric and process parameters and thus suitably optimizing the factors of these parameter would result in better tool life.

V. OBJECTIVES

The main objectives are listed below:

1. To approximately calculate the tool life for face milling tool;
2. To know the output response corresponding to the input parameters so as to optimize the important parameters;
3. To compare analytical data and experimental data.

VI. MATERIAL AND METHODOLOGY

a) Workpiece

The work piece used will be Nickel Steel Die material which is oil hardened. It is also referred as OHNS i.e. Oil Hardened Nickel Steel. Its chemical composition is tabulated below:

Table 1: Chemical Composition of OHNS Die material

Steel type	Quality	AISI	Typical analysis in %				
			C	Mn	Cr	W	V
OHNS die Steel	OHNS	01	0.95	1.00	0.50	0.5	0.10

b) Machine

The experiment can conducted in any Vertical Machining Center.

c) Machine Tool

Face milling will be performed on the work piece with the help of a face milling cutting tool. The tool will be provided with 2 slots for attaching inserts. The inserts will have 4 cutting edges which will be used to remove the material from the surface of the work. Inserts may be either brazed or simply screwed with the help of M4 screws.

d) CONSIDERATIONS

Out of all the mentioned objectives, the main objective is to increase the tool life which is dependent on different parameters. In this experiment, it would be done by varying the process parameters i.e. feed rate, depth of cut and cutting speed. On varying these parameters, the surface roughness will be investigated on each run. The above mentioned parameters are only considered due to difficulty that arises on selecting other parameters. Limiting factor could be taken as an area for face milling. Since inserts would be used to remove the material during the face milling, measuring the cutting radius of the insert would be used to determine the tool life of the cutter.

VII. CONCLUSION

By varying the process parameters, the cutter radius of the insert is measured to identify the wear caused to it during the removal of the material from the work. This way best suitable parameters can be selected which results in the minimum wear of the tool. On selecting the optimized parameters, the cutter radius of the insert is reduced least and the tool life is increased. With the aid of the RSM, it can be proved theoretically

VIII. REFERENCE

1. S NizamSadiq, T R Raguraman, D Thresh Kumar, R Rajasekaran and T T M Kannan, "Optimization Of Milling Parameters Of OHNS Steel Using Tialn Coated Cutter By Design Of Experiment Technique", International Journal of Mechanical Engineering and Robotics research, Vol. 3, January 2014.
2. Nitin B. Katrodiya and Harshad D. Patel, "Investigation of the Effect of Cutting Parameter by Using Different Cutting Path for End Milling Operation on Surface Roughness", IJSRD - International Journal for Scientific Research & Development, Vol. 2, Issue 03, 2014.
3. Kannan. S, Baskar. N, "Modeling and Optimization of Face Milling Operation Based on Response Surface Methodology and Genetic Algorithm", International Journal of Engineering and Technology (IJET), Vol5 Oct-Nov 2013.
4. B.R.Dabhi, K.V.Parmar, "A review paper on latest trend on face milling tool"
5. Prasanna P Kulkarni, Kiran J O, Deeleepkumar S G, "Effect Of Tool Nose Radius And Cutting

Parameters On Tool Life, Surface Roughness In Turning Of Grey Cast Iron”, Vol. 6 Mar 2014 .

6. N. S. Pohokar and B. B. Bhuyar, “Tool life Estimation of CNC End milling Tool by Optimizing Geometry and Machining Parameters”, International Journal Of Mechanical Application Research (IJMEAR), Vol -3, Oct-Noc 2012.
7. M. Subramanian, M. Sakthivel, K. Sooryaprakash, R. Sudhakaran, “Optimization of end mill tool geometry parameters for Al 7075 – T6 machining operations based on Vibration amplitude by response surface methodology”, Measurement 46(2013) 4005 – 4022.
8. Z.O. Liu, X. Ai, H Zhang, Z. T. Wang, Y Wan, “Wear patterns and mechanisms of cutting tools in high speed face milling”, Journal of material processing technology 129(2002)222-226.

