

# Design and Simulation of Permanent Magnet Linear Generator for Wave Energy Power Plant

Aung Myo Naing

Electrical Power Engineering Department, Technological University, Hmawbi, Yangon, Myanmar

**How to cite this paper:** Aung Myo Naing "Design and Simulation of Permanent Magnet Linear Generator for Wave Energy Power Plant" Published in International Journal of Trend in Scientific Research and Development (ijtsrd), ISSN: 2456-6470, Volume-3 | Issue-4, June 2019, pp.1202-1206, URL: <https://www.ijtsrd.com/papers/ijtsrd25108.pdf>



IJTSRD25108

## ABSTRACT

This paper proposes a linear generator, which can convert any mechanical energy (wave or other vibration) to electric energy. A mover of the proposed linear generator, which includes permanent magnets, is linearly driven through a stator, by wave energy. Nd-Fe-B magnets in the mover are placed so that the same magnetic poles face each other, in order to make the large change in magnetic flux in the coils of the stator. Therefore, the magnetic flux is extended through the case and reduces cancellation of the flux in the coils of the stator.

In this paper permanent magnet linear generator is proposed and analyzed by means of numeric field computations and FEMM Software. It was designed for wave power energy systems to be placed in the coasts.

Copyright © 2019 by author(s) and International Journal of Trend in Scientific Research and Development Journal. This is an Open Access article distributed under the terms of the Creative Commons Attribution License (CC BY 4.0) (<http://creativecommons.org/licenses/by/4.0>)



**Keywords:** Linear generator, Wave energy converters, Permanent magnet variable machines, Renewable energy resources, Wave energy

## I. INTRODUCTION

It is crucial for the man kind to develop clean renewable energy resources. We cannot indefinitely continue to base our life on the consumption of finite energy resources, as those based on fossil fuels and nuclear power. These sources of energy will not last forever and have proven to be one of the main causes of all the environmental problems.

Renewable sources of energy are in line with an overall strategy of sustainable development. They help reduce the dependence of energy imports, and also help improve the competitiveness of industries and have a positive impact on regional development and employment [1].

Renewable energy sources include hydropower, biomass, solar, wind, geothermal, and ocean energy. The rapid deployment of renewable energy technologies and their larger development in the near future, raise challenges and opportunities regarding their integration into energy supply systems.

Together the renewable energy sources currently contribute the equivalent of 7% of the World's primary energy use. Day by day the share of renewable energy in electricity consumption is increased. For this the EU has set a target of 12% by 2010. As a result of the political commitments the renewable energy industry is developing around the world being one of the highest priorities of mankind.

The mover of the proposed linear power generator is devised to increase the change in magnetic, in order to generate power more efficiently. To be specific, the mover structure consists of Nd-Fe-B magnets placed so that the same magnetic poles face each other. The stator was covered

with a magnetic metal case that has pole pieces between the coils. Therefore, the magnetic flux is extended through the case and reduces cancellation of the flux in the coils of the stator.

In this paper, the fundamental structure of the linear power generator will be described. Numerical simulations were used to calculate the distribution of the magnetic field and electromotive force in order to determine the ideal size of the linear power generator. The linear power generator and an experimental apparatus were then produced on the basis of this simulation. Its effectiveness in power generator will be confirmed by examinations.

## II. Linear Generator Configuration

### A. General description of power plant

A possible WEC concept with a linear generator as power take-off is shown in Fig.1 and 2. The WEC consists of a buoy coupled directly to the rotor of a linear generator by a rope. The tension of the rope is maintained with a spring pulling the rotor downwards.

For example, a 10 kW generator needs a reaction force in the order of 10 kN with a rotor speed of 1 m/s. This implies that a directly driven generator must be larger than a conventional high-speed generator.

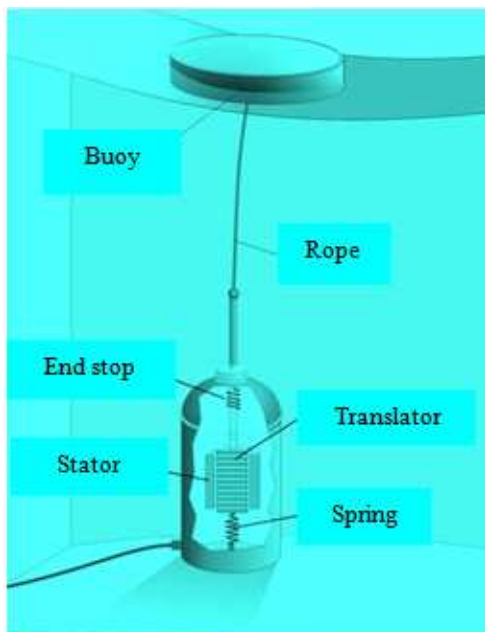

Fig.1 The principles of a wave energy plant with a linear generator.

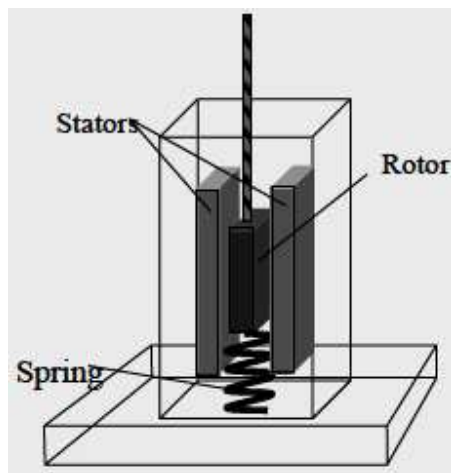

Fig.2 Cross-section of the linear generator

**B. Stator**

The stator is made of laminated electrical steel, piled into one solid unit, see Fig.3.

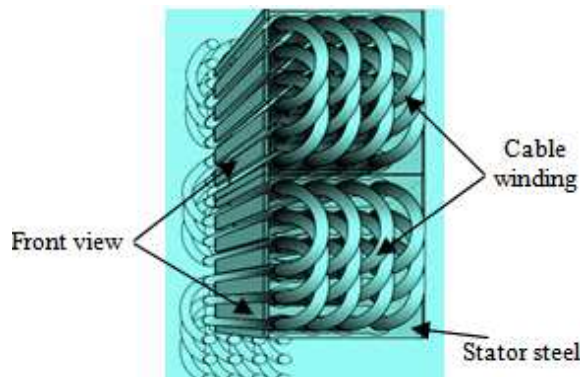

Fig. 3 Tilted side view of a section of the stator.

The conductors are power cables with a circular cross-section and a conducting area of 16 mm<sup>2</sup>, insulated with a 1.1 mm PVC-layer, which adds up to an outer diameter of 7.2 mm. The coil winding is a three-phase winding with a slot per pole and phase ratio of 5/4. This winding configuration

aims at minimizing the fluctuation in the output power caused by cogging. A three-phase LFM with a slot per pole and phase ratio equal to one is proposed as generator in the Archimedes Wave Swing [1].

**C. Rotor**

Two types of magnet fixation methods, surface mounting and burying magnets between pole shoes, are tested with two different types of permanent magnets. The two fixation methods are illustrated in Fig.4. In both configurations adjacent magnets have opposite polarity and a movement of the rotor creates an altering magnetic field in the stator coils.

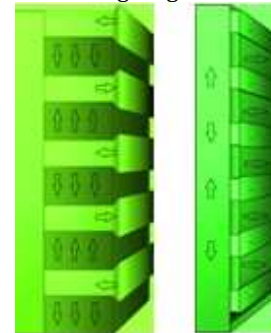

Fig.4 Tilted side view of rotor for a LFM linear generator

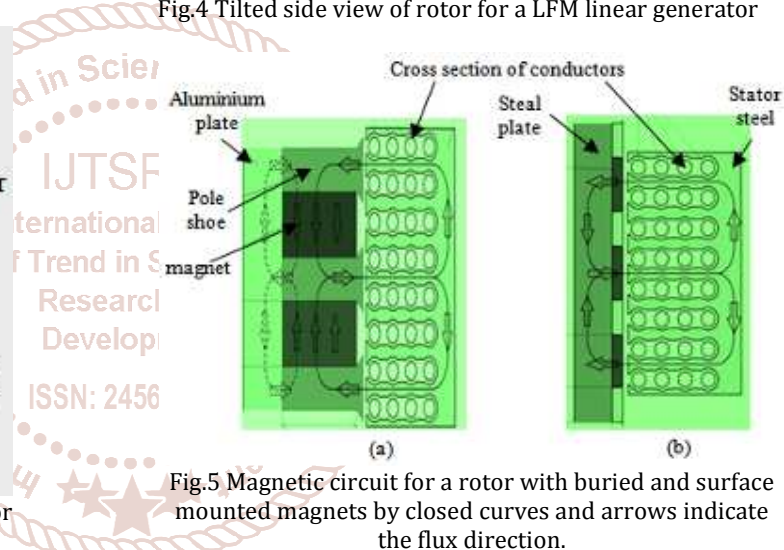

Fig.5 Magnetic circuit for a rotor with buried and surface mounted magnets by closed curves and arrows indicate the flux direction.

Fig.5 (a) shows the magnetic circuit of a rotor with buried magnets. The flux is led from the magnets through bars of magnetic steel, called pole shoes. The pole shoe enables control of the magnetic flux distributions in the periphery of the air gap and it also protects the magnets from transient magnetic fields generated by short circuit in the outer circuit. The aluminium plate on the backside of the rotor serves as a barrier for the magnetic flux to pass through the backside of the rotor. A portion of the magnetic flux will unavoidably pass through the back. That flux will not contribute to the magnetic coupling and can be considered as “lost”.

The magnetic circuit of a generator with surface mounted magnets are illustrated in Fig.5 (b). Surface mounted magnets are more exposed to transients and face a larger risk of demagnetization. On the other hand the magnetic circuit has no obvious shortcuts, as is the case for the buried magnets.

Two permanent magnets have been examined: ordinary ferrite (Fe) magnets and high-energy Neo-dymium-Iron-Boron (NdFeB) magnets. The basic properties of the magnets

are presented in Table (1). NeFeB magnets are considerably more expensive than Fe magnets and the relation of the kilo price is assumed to be 10:1.

**TABLE I Properties of the Magnets**

Material	Neodymium-Iron-Boron (Vacodym 633 PT)	Ferrite Magnet (Oe Magnet Y30 BH)
Remanence	1,32	0,3663
Relative Permeability	1,06	1,06
Density (kg/m <sup>3</sup> )	7700	4700

### III. Design Calculation Of A PMLG

The proposed design procedure utilizes the rotating machine design by converting the specifications of the linear machine. A standard or classical design procedure begins with the power output equation relating the machine dimensions such as diameter, lamination stack length, speed, magnetic loading and electric loading.

Future, the machine dimensions and their impact on performance are characterized by implicit relationships and made available in a form to enable machine design.

Analytical expressions relation machine dimensions to output variables are required for a linear machine design. The longitudinal linear configuration of a three-phase machine with an active stator and passive translator is designed in this paper.

A permanent magnet linear generator configuration is designed for the following specifications.

The electromagnetic force,  $F=1450\text{ N}$

The maximum linear velocity (speed),  $v = 0.5\text{ m/s}$

Type of permanent magnet is Nd-Fe-B that value remanent magnetic flux density,  $B_r = 1.2\text{ T}$

The coercive force  $H_c = 900\text{ kA/m}$

The secondary core made of solid iron with infinitive permeability,  $\mu = \alpha$

Permissible flux density,  $B_{y2} = 1.2\text{ T}$

Air gap:

Airgap flux density,  $B_g = 0.85\text{ T}$

Airgap length,  $g = 1\text{ mm}$

If the wave power (mechanical power) loss is ignored, the average in put power of the generator,

$$P_{in} = Fv = EI$$

In a generator there are three kinds of losses;

1. Core loss, due to the change of magnetic field; these losses take place in the stator steel, and they consist of the hysteresis losses and the losses due to the eddy currents.

2. Copper losses; they are resistive losses in the coil windings
3. Mechanical losses due to friction and ventilation.

The copper (resistive) losses, which are the only losses considered in this application, appear in the conductor with the electrical resistance,  $R_{\phi T}$  carrying a current,  $I$ :

$$\Delta P = 2R_{\phi T} I^2$$

The output power;  $P_o \cong V_{out} I$

and the generator efficiency;

$$\eta = \frac{P_{out}}{P_{in}} \cong \frac{P_{out}}{P_{out} + \Delta P_c}$$

The length of the primary winding depends on the tooth pitch  $\tau_1$ , the numbers of turns per phase  $N_p$ , the numbers of turns per coil  $N_c$ , and the number of phases  $m$ ,

$$l_{prim} = \tau_1 \left( \frac{N_p}{N_c} \right) m$$

The length of the active part of the secondary must be the same as the length of the primary. It depends on the pole pitch  $\tau$  and on the number of the pair poles,  $P$ ,

$$l_{sec(active)} = 2P\tau$$

Since the secondary part moves, and in order to have the same active part during the oscillation, the real length of the secondary must be greater than the primary. In this case, the secondary will have two more pair poles,

$$l_{sec} = 2(P+2)\tau$$

The air gap PM flux density in the air gap  $B_{gPM}$ , is

$$B_{gPM} = \frac{B_r \times l_{PM} \times \mu_{rec}}{l_{PM} + (g + h_{coil}) \times \mu_{rec}} \times \frac{1}{(1 + k_{fring}) \times (1 + k_s)}$$

In general, for a good design,  $k_{fring} < 0.3-0.5$   $k_s$  takes care of magnetic saturation and is generally less than 0.05 to 0.15 in a well-designed machine.

The emf in the  $2p_1$  coils in series,  $E$  is as follows:

$$E(t) = B_{gPM} \times v(t) \times \pi \times D_{avc} \times 2pN_c \left( \frac{l_{PM}}{l_{PM} + l_{stroke}} \right)$$

The machine inductance  $l_s$  and resistance  $R_s$  are

$$L_s = \frac{1}{4} p \mu_0 N_c^2 \pi D_{avc} \frac{l_{PM} + l_{stroke}}{(h_{PM} + g + h_{coil})}$$

$$R_s = \rho_{co} \pi D_{avc} \frac{N_c^2 2p}{(I_n N_c^2) j_{con}}$$



**TABLE II Calculated Design Of Stator And Translator Data**

No.	Design Parameter	Calculated Value
1.	Output voltage	59.3 v
2.	Output current	12 A
3.	Power Capacity	330 w
4.	Vertical length of primary	280 mm
5.	Vertical length of secondary	420 mm
6.	Secondary core length, $l_2$	48 mm
7.	Secondary core length, $l_{y2}$	40 mm
8.	Thickness of the permanent magnets, $l_m$	4 mm
9.	Length of tooth, $h_t$	244 mm
10.	Thickness of the primary yoke, $w_{y1}$	3 mm
11.	Length of the primary yoke, $l_{y1}$	24.85 mm
12.	Length of the primary outer yoke, $l_{yo1}$	27.85 mm
13.	Number of turns in a coil, $N_c$	70
14.	Number of pole	4
15.	Number of slot per per pole, phase	5/4

**IV. Result Of Performance And Magnetizing Field**

The generator’s shaft is made of non-magnetic steel. On the shaft are fixed permanent magnets that are separated by ferromagnetic pieces. The stator has 6 slots in which are placed 6 flat coils of a three-phase winding with 2 coil on each phase.

The rotor’s length is greater than the stator’s one. The rotor is moving along the symmetry axle with a low frequency of a few hertz equal to the one of the waves. The numerical modeling of the magnetizing field is performed with the conjugated gradient method using the FEMM software [5].

The influence of the permanent magnet with over the magnetizing field for a fixed position of the rotor beside the stator and the rotor’s position influence over the stator for a fixed width of the permanent magnets are analyzed.

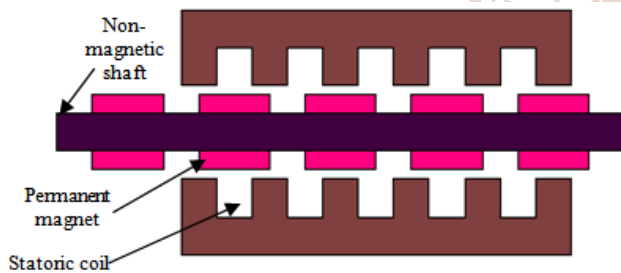

Fig.6. The linear generator’s sketch

The oscillatory movement of the rotor is obtained using a rod winch mechanism. The generator model is operating horizontally.

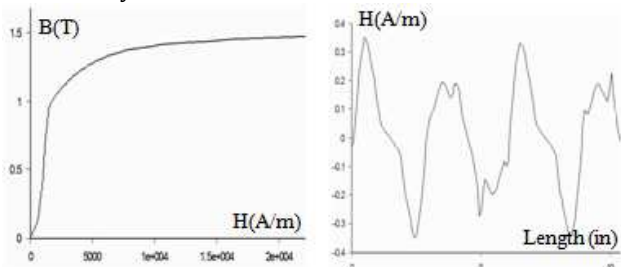

Fig.7 The magnetizing characteristic of B-H and Flux Density curve

This Fig.7 is presented material characteristic of ferromagnetic material. The permanent magnets are considered to be NdFeB and have the following specifications: permeability  $H_c=979000A/m$ ; relative magnetic permeability  $\mu_r=1.049$ ; maximum magnetic energy  $BH_{max}=40MG0e$ ; electrical conductivity  $\sigma=0.667MS/m$ . the average speed of the rotor for half of maximum displacement is about 0.106m/s, and the average thrust force about 38.73N. the experimental model generates at stator terminals an electric power 6.787W.

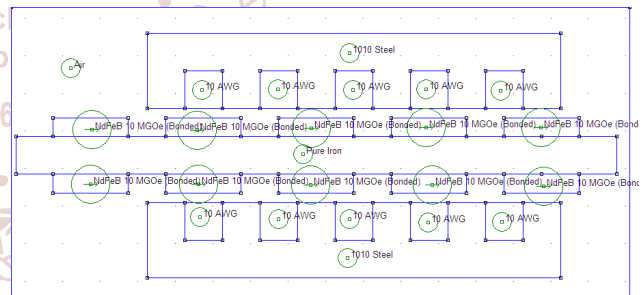

Fig.8. Real data of PMLG for magnetizing field

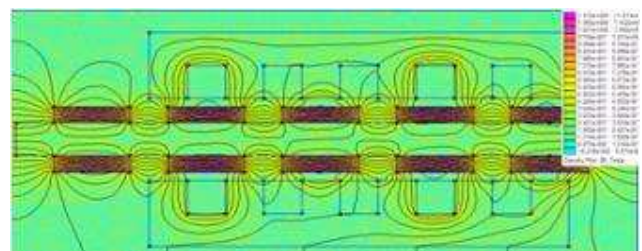

Fig.9 The magnetizing field’s map for flux density

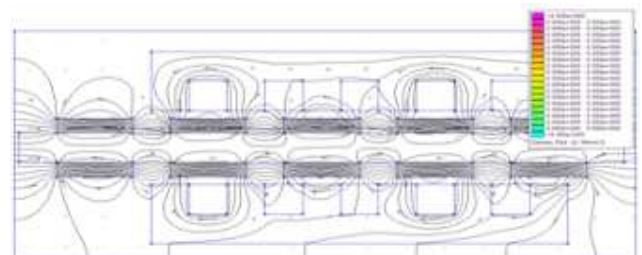

Fig.10 The magnetizing field’s map for current density

In this case of the alignment of the magnet axis with the central statoric tooth axis it happens a special phenomenon. That is, the magnetic field lines of the magnet aligned with the statoric tooth, due to the symmetry, do not close along this tooth and so the flux density of this tooth is quite low about 0.15 T. In exchange, the area of the statoric tooth towards the air gap is saturated, the flux density is about 2.9 T. A lot of magnetic field lines are running through the statoric teeth in neighborhood producing saturation of the areas towards the air gap. The flux density from these zones is around 1.96T.

#### V. Conclusion

The paper shows to the linear generators with permanent magnets manufacturers, useful information regarding the most endangered zones from a magnetic point of view. It also presents the values for the forces that are the dangerous ones for the generator. The optimal width of the permanent magnet is determined in order to obtain the maximum possible value for the efficiency of the generator. The results presented in the paper are based on the computation of the magnetic field and on the forces that act over the different parts of the generator. The magnetic field was obtained using the finite element method with the help of FEMM software.

#### Acknowledgment

Firstly, the author would like to thank my parents for their best wish to join the Ph.D course at MTU. The author would

like to express his gratitude to Dr. Nay Soe Shwe, Head of Department of Electrical Power Engineering and to his teachers from Mandalay Technological University. The author greatly expresses his thanks to all persons whom will concern to support in preparing this paper.

#### References

- [1] Mats Leijon, Hans Bernhoff, Olov Agren, Jan Isberg, Jan Sundberg, Marcus Berg, "Multiphysics Simulation of Wave Energy to Electric Energy Conversion by Permanent Magnet Linear Generator", IEEE TRANSACTIONS ON ENERGY CONVERSION, VOL. 20, NO.1, MARCH 2005.
- [2] Jan Vergauwe, André Martinez, Alberto Ribas, "Optimization of a wind turbine using permanent magnet synchronous generator (PMSG)", ICREPQ'06.
- [3] SAN MARTÍN, José Javier, ROMERO, Eduardo; ZUAZUA, Jon; APERRIBAY, Víctor; SAN MARTÍN, José Ignacio; ARRIETA, José M<sup>a</sup>; MARTÍN, Iñaki, "Generation and store of aeolian energy in form of Hydrogen using multipole aeolian generators", ICREPQ'06.
- [4] Danielsson, O., Wave Energy Conversion - Linear Synchronous Permanent Magnet Generator, Ph.D. Thesis
- [5] Finite Element Method Magnetics. <http://femm.foster-miller.net/>.

