



A Survey Paper on Car Parking Reservation System for Parking Slots using Android Application

Mr. Raghuveer Raibagi¹, Mr. Vivek Khubchandani¹, Mr. Aniket Ahuja¹,
Mr. Kantesh Pidwani¹, Mr. Sagar V. Chavan²
¹Student, ²Professor

Department Computer Science and Engineering,
Sanjay Ghodawat Polytechnic, Atigre, Maharashtra, India

ABSTRACT

These days with the fast increment in urban populace, there is a noteworthy issue with the parking framework in relatively every real city over the globe. Numerous of us get exceedingly exasperated when there is no appropriate space for parking spot for our vehicles. In this article, we have proposed a brilliant parking application, where clients will be ready to stop their cars by finding a void parking garage through Android Application or can even stop their autos specifically through Embedded Hardware. An Intelligent Parking System is executed in light of Opening Allotment. There are two modes utilizing which the Android client can book the stopping openings effortlessly like Advance and Current Booking. Utilizing these modes the application client can likewise pick the most effortless and closest course and goal. The Android Application itself will fill in as an payment portal. Implanted Hardware is actualized for Direct Parking. Server will screen the Space Allotment powerfully.

Keyword: *IoT (Internet of Things), Infrared sensor, RFID (Radio-Frequency Identification), Wireless sensor, Wireless sensor network (WSN), ZigBee.*

1. INTRODUCTION

The spread in Information and Communication Innovation (ICT, for example, remote sensors has presented new and exceptionally existing applications in all aspects of life. These applications either from machine-to-machine (M2M) or Person to-machine (P2M) have improved the expectations for everyday comforts. Other than it has incorporated the benefits of diminished better security and more manageable innovation. Wireless sensor network (WSN) is

exceptionally clear in the ebb and flow investigate and advancement writing as far as shrewd urban areas where the different applications are incorporated together with the assistance of the enhanced innovation.

These days with the expanded populace in the urban communities, car park has turned into a noteworthy issue. This issue can be overwhelmed by the present day innovation. In the specific situation, an android application is produced for brilliant auto stopping. In this android application, openings can be reserved for stopping the vehicle. Booking can be done in three different ways as Current booking, Advanced booking, Direct reserving. Online payment should be possible for the booked spaces utilizing the android application. There is a RFID (Radio-frequency Identifier) that is utilized for accommodating that the booked vehicle has landed in the specific space. Radiofrequency ID (RFID) utilizes the electromagnetic fields to exchange information naturally by recognizing and following the connected items. These labels will contain the electronically put away data. A few kinds of labels gather vitality by cross examining radio waves and they fill in as a inactive transponder. The client will likewise determine the day and age for which he needs the slot to be reserved.

2. LITERATURE REVIEW:

2.1 Hongweiwang and wenbohe(Feb 2011) “A Reservation based smart car parking system” In this paper we design and implement a prototype of reservation based smart car parking system that allow drivers to effectively find and reserve the find vacant

parking space. By periodically learning the parking states from the sensor networks, deploy in parking lots, the reservation service is affected by the change of physical parking status. The drivers are allow to access this cyber physical system with their personal communication device. The experiment results show that the proposed reservation based parking policy has the potential to simplify the operation of parking system. We implement parking reservation policy to balance the benefit of service provider and requirements from the user. We conclude that the proposed the reservation based smart car parking system can alleviate traffic congestion caused parking searching and reduced the amount of traffic volume searching for parking.

2.2 Renuka R and S. Dhanlakshmi(April 2014),“Android based smart car parking using slot allocation and reservations” This paper proposes an android application, which is used to implement a prototype of smart car parking system based reservation that allows driver to effectively find and reserves the vacant parking spaces with the help of IOT with slot allocation method and performs automatic billing process. The proposed system guides drivers to find available parking space near them, less number of drivers searching to park, thus it reduces traffic congestion, it avoids air pollution and global warming, it is scalable robust and reliable, it reduce the drivers stress and improves urban area, it provides tools to optimize the parking space management, it is accurately find out the vehicle occupancy in real time. The main contribution of our proposed system is to find out status of parking area and provides secure parking.

2.3 D. J. Bonde, Rohit Sunil Shende (Jan 2014), “Automated car parking system commanded by android application” The aim of this paper is to automate the car and the car parking as well. It discussesa project which present a miniature model of an automated car parking that can regulate and manage the number of cars that can be parked in a given space at any given time based on the availability of parking slot. Automated parking is a method of parking and existing cars using sensing devices. The entering to or leaving from the parking lots is commanded by an android based application. The difference between our system and other existing system is that we aim to make our system as less human dependent as possible by automating the car as well as the entire parking lots on the other hand most

existing system required human personal to park the car themselves.

2.4 KishoreK. Chidella, MuhammadF.Mridha (April 2015) “A Time and Energy efficient parking system using zigbee communication protocol” This paper proposes a smart parking system for heavy traffic environments using zigbee wireless transmission module. The proposed system is suitable for multi floor building and able to send and send a message to vehicles about the status of parking space. The parking monitoring system continuously collect the data from parking slot detector and then it intiements the vehicle section. We simulate the proposed system using Zigbee and to other popular wireless technologies: Bluetooth and Wi-fi, experimental results show that Zigbee provides transition time and power advantages over Bluetooth and Wi-fi.This system can be implemented in the future cars and can be used to avoid the traffic problems in the heavy parking areas like the shopping malls and other busy area. The reduced traffic problems saved the fuel and this reduced the cost and population. This project also saves the time in finding the parking space. In this paper we study data gathering protocol within a level, services using car parking framework, illegal parking detection services and security services. This paper addresses the issue of automation and modernization of car parking management by proposing a Car Parking Framework (CPF), and assessing its relevance with respect to the engineering and economic efficiency.

3. OBJECTIVE & SCOPE:

- To increase efficiency of the current cloud-based smart-parking system.
- To track the nearest car parking place via GPS.
- To book available free parking space in cloud.
- To reduce time and efforts of drivers.
- To update and send notification to user of available space

Problem definition:

In order to propose and implement an smart-parking system based on Internet of things and commanded by Android application using IR Sensors that helps automatically find free parking space based on the parameters of performance that makes the system cost and time efficient. The parking slots which are available should be sensed and can be updated on an IoT database so that every user connected with the

database can identify free parking slots in a specific location.

Proposed work:

In the second stage the client will go straightforwardly to the parking space part and demonstrate their RFID TAG. The vehicle comprises of a RFID tag. This is perused by the reader in the Gate area. This esteem is transmitted to the parking area segment through a zigbee handset or Li-Fi handset. A microcontroller in the entryway area stores and updates the void lot number at whatever point vehicle leaves a parking lot. A RFID label relating to this free parking lot is given to the vehicle which is entered in the door area prior. The vehicle at that point goes to the parking area segment. This area has a RFID reader to check both the vehicle's tag and the vacant part's tag. So the client will be ready to stop their vehicle in the free parts. This will be refreshed in the server. IR sensor is utilized here to identify whether the space is free or not. The sensor which is interfaced with controller is likewise refreshed.

4. METHODOLOGY:

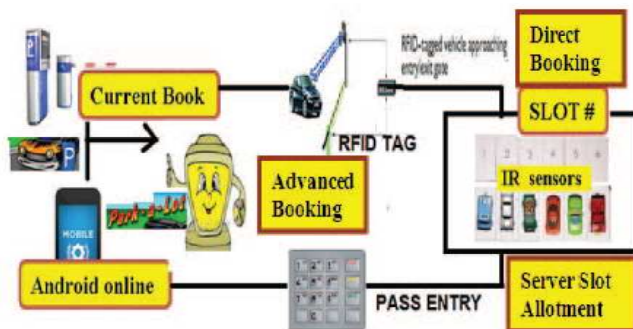

Flow Chart

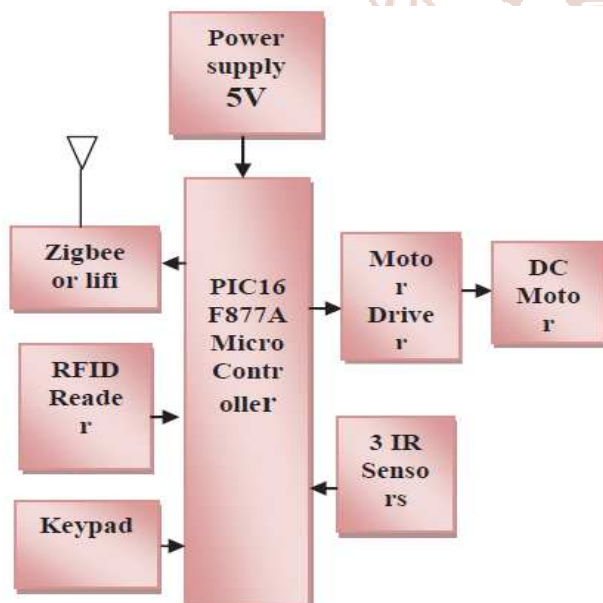

5. CONCLUSION:

There is an incredible trouble met by the general population today in finding an unfilled opening for parking their vehicles. A great deal of time is spent to locate an unfilled opening for stopping the car. In this specific circumstance, we build up a successful parking reservation framework where the client can book their specific space utilizing their android application or with the assistance of implanted equipment. This framework is profoundly solid and proficient. This framework can be used to stay away from overwhelming movement in the parking regions like shopping centres, theatres, vacationer spots and other occupied zones in this way less time and the utilization of the fuel and contamination. Digital security to the parking cloud benefit must be actualized in our future undertakings as there are numerous security risks involved continuously usage of both cloud server and IoT.

6. REFERENCES

1. Igor Bilogrevic, MurtuzaJadliwala,Vishal Joneja, "Kubra K Privacy- Preserving Optimal Meeting Location Determination on Mobile Devices," IEEE Transactions on Information Forensics and Security, vol. 9, no. 7, pp. 1141-1156, JULY 2014.
2. P. Golle and K. Partridge, "On the anonymity of home/work location pairs," in Proc. 7th Int. Conf. Pervasive Computing, pp. 390397, 2009.
3. J. Freudiger, R. Shokri, and J.-P. Hubaux, "Evaluating the privacy risk of location-based services," in Proc. 15th Int. Conf. Financial, pp. 3146, 2011.
4. J. Freudiger, M. Jadliwala, J.-P. Hubaux, V. Niemi, P. Ginzboorg, and I. Aad, "Privacy of community pseudonyms in wireless peer-to-peer networks," Mo- bile Netw. Appl., vol. 18, no. 3, pp. 413428, 2012.
5. J. Krumm, "A survey of computational location privacy," Personal Ubiquitous Computing, vol. 13, no. 6, pp. 391399, 2009.
6. K. B. Frikken and M. J. Atallah, "Privacy preserving route planning," in Proc. ACM WPES, pp. 815, 2004.