



OTA Based Second Order Active Filter Realizes Lowpass, Highpass, Band Pass and Band Reject Filters

Vijay Laxmi Kalyani, Vartika Gupta, Harshita Khandelwal, Teena

DOI 10.5281/zenodo.1407359

Vijay Laxmi Kalyani, Assistant Professor and former HOD, Govt. Women Engineering College Ajmer, India

(vijaylaxmikalyani@yahoo.com).

Vartika Gupta, B.Tech, III -year,(EEE), Govt. Women Engineering College Ajmer, India

(Vartikagupta1267@gmail.com)

Harshita Khandelwal, B.Tech III-Year, (EEE), Govt. Women Engineering College Ajmer, India

(harshitakhandelwal513@gmail.com)

Teena, B.Tech, III-Year, (EEE), Govt. Women Engineering College Ajmer, India

(Teenamandrawaliva1@gmail.com)

Abstract: Due to the good controllability and electronic tunability features, OTA is used for designing of active filters. OTA based active filters required minimum component in comparative to other analog building blocks. In this paper, OTA based second order active filter is presented which realizes Low pass filter, High pass, Band pass and Band reject filters. The proposed circuit is designed using CA3080 IC on 20 KHz frequency so that it can be suitable for audio frequency ranges (0-20 KHz) and the peak to peak voltage is used 30 mV. Simulation results and PCB Layout, 3-D View are also shown so that it can be implemented on hardware. The NI-Multisim software and ultiboard is used for simulation results and PCB layout.

KEYWORD:-OTA, active filters, CA 3080 IC, Simulation results, NI-multisim, Ultiboard

I. INTRODUCTION

OTA have received considerable attention in the literature [1-4] due to its simple structure, electronic tunability, higher frequency range of operation. OTA is the voltage controlled current source (VCCS). OTA has good controllability features with voltage variable control through input current I_{ABC} and it can operate on higher frequency ranges. OTA based active filters require minimum components hence the circuitry is simpler and can be implemented in IC designing. Several design of active filters have been proposed by using OTA in the literature [1-4]. In (Rahul Kumar et al,2014), the authors presented a universal filter using operational transconductance amplifier with three inputs and one output using two single ended OTAs and two capacitors. In (Ghanshyam Singh, D. R. Bhaskar and Dinesh Prasad, 2015), the authors proposed a new current mode (CM) single-input and multi-output (SIMO)-type biquad using two multiple output OTAs and one current follower as an active device and having two grounded capacitors. In (Rajeshwari S. Mathad, M. M. Mutsaddi and Manjula V. Katageri, 2015), the authors presented a second order OTA-C filter based on OTA integrator and register is selected as a suitable

structure in the design of universal filter by selecting proper inputs V_A , V_B and V_C . In (Manish Gupta, 2016), the author proposed a new current mode (CM) single-input and multi-output (SIMO)-type biquad using two multiple output OTAs and one current follower as an active device and having two grounded capacitors.

In this paper, OTA based active filter is presented which realizes Low pass filter, High pass, Band pass and Band reject filters. The proposed circuit is designed using CA3080 IC on 20 KHz frequency so that it can be suitable for audio frequency ranges (0-20 KHz) by changing the transconductance g_m without disturbing the other component value and the peak to peak voltage is used 30 mV. Using OTA circuit design is very simple because it requires few components only. The proposed circuit uses two OTA and two capacitors only and this circuit has three inputs (V_1, V_2, V_3) and one output (V_0). Hence it is also referred as multiple input single output (MISO) OTA based circuit. In this paper, the CA3080 IC (OTA) is used for circuit designing. Simulation results and PCB Layout, 3-D View are also shown so that it can be implemented on hardware. The NI-Multisim software and ultiboard is used for simulation results and PCB layout.

II. OPERATIONAL TRANSCONDUCTANCE AMPLIFIER (OTA)

OTA is extensively used to make with linear and non-linear analog signal processing circuits. It gives an electronic tunability, a broad range of its transconductance gain and manageable circuitry. The most attractive characteristics of OTA is programmability. The operational transconductance amplifier (OTA) is explain as the input voltage produces an output current. It has a voltage controlled current source (VCCS). There is generally an additional input for a current to control the amplifier's transconductance. The OTA is almost identical to a standard operational amplifier. It contain a high impedance differential input stage.

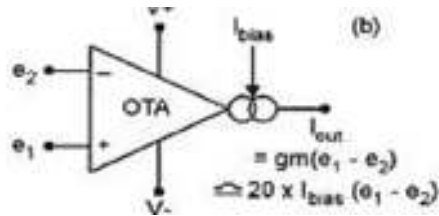

Fig (i) CA3080IC in OTA

It is a voltage to current amplifier. It has 2 differential voltage input terminal (e1 and e2). The negative terminal indicates by constant current in its output and then input voltage produce a high impedance output the value is $g(m)(e_1 - e_2)$

- $g(m)$ = transconductance
- I_{bias} = external bias current
- V+ and V- = supply terminal
- I_{out} = output current

A Voltage to current is essentially an amplifier that has an ability of producing a proportional to an applied input voltage. The output current which produced by an amplifier which is a voltage to current convertor using op amp is dependent on the input voltage. The transconductance of an amplifier circuit is refer to its proportionality constant, that's why this circuits are known as transconductance amplifier. specified design single chip transconductance amplifier IC are accessible in the market. These IC are used in large scale in the design of programmable amplifier and integrator in audio processor and electronic music analysis application. they also discover use as current switches in sample and hold application. The mostly used OTA are CA3080 from Intersil, LM13600, LM13700 from national semiconductor and NE5517 from signetics.

In this paper to design the active filters, CA 3080 OTA IC is used. This IC has several features which are discussed below:

This CA3080IC is like a conventional operational amplifier. It consumed power when system is in ON state. It doesn't consumed any power at OFF channel. It is one of the best IC, because it has a particular value in making of micro-power voltage comparator, oscillator or voltage and controlled amplifier. It have one differential amplifier and four current supply. It have a high impedance and their transconductance (g_m) of amplifier is directly proportional to its amplifier bias current (I_{ABC}).

$$g(m) = \frac{I_{ABC}}{V}$$

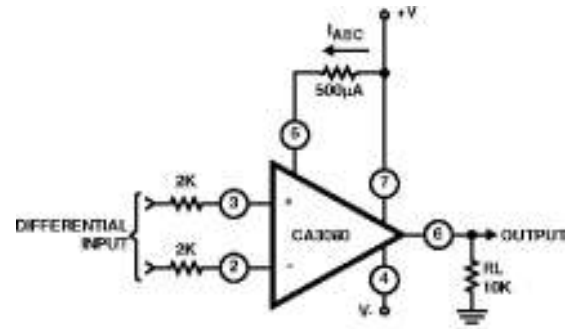

$$A = g_m R_L \text{ at } 500\mu A, I_{ABC}$$

$$g_m = 10mS$$

$$\therefore A = 10mS \times 10K = 100$$

Fig(ii) schematic diagram of CA3080IC

This CA3080IC, I_{ABC} can be varied up to 0.1 μA to 1mA.

FEATURES OF CA3080 IC:-

- Its slew rate is 50V/ μs .
- It Power consumption range is 10 μW to 30 μW .
- It is fully adjustable gain up to gmR_L .
- It gm linearity extended up to 3 decade.
- It have full temperature range i.e. (-55 C to +125 C).
- Common mode rejection ratio (CMRR) is 100db
- Its bandwidth is 2 MHz
- Amplifier bias current is 2mA
- Input signal current is 1mA
- Its supply voltage is up to $\pm 2 V$ to $\pm 15V$.

At the room temperature the current I_C driven into pin 5 is control the transconductance (g_m).

$$g(m) = \frac{I_C}{V}$$

Where $V_T = 26mV$ at room temperature and V represents Volt per unit indication.

The unit of transconductance (g_m) = Siemens.

Charge current (I_C) = 0.1 μA < I_C < 400 μA .

It is known that

$$I_o = g_m V_1 = g_m (V_1 - V_2)$$

Thus,

$$I_o = \left(\frac{I_C}{V} \right) V_1$$

For IC CA3080, the value of I_C is $I_C < 400 \mu A$ and $V_1 < 20 mV$ the equation is linear. It will not remain straight when the value of input voltage (V_i) > 20mV. The input voltage (V_{in}) must be reduced to less than 20 mv of value.

Due to its good controllability features with voltage variable control through the I_{ABC} input. The OTA can be used for constructing active filter. For detecting the critical frequency or 3db frequency of the filter, the OTA based active filter can be higher for external biased position. The circuit can be design for independent gain and critical frequency setting. The structure of the filter response can also be protect by employing the OTA based filter. A simple first order low pass filter with one pole corresponding to a roll off rate of -20db per decade. the voltage gain over whole of the frequency range, and the -3db frequency is given



by

$$\frac{V_o}{V_i} = \frac{gm}{sC + gm}$$

F3db=—

III. SECOND ORDER ACTIVE FILTERS USING OTA

The second order active filter with three voltage control terminals (V_a, V_b, V_c), one output (V_o) and two capacitors using two OTAs has been designed in this paper. By selective grounding of two of the terminals of input voltages (V_1, V_2, V_3), low pass, high pass, band pass and band reject (notch filter) responses can be realized. The critical or centre frequency can be set by varying the transconductance G_m of the two OTAs connected in the circuit. These filters are called adjustable frequency constant-Q filters, since they preserve the value of Q even when the critical frequencies are shifted. The general relationship between the output voltage and the three control voltages can be derived as follows:

$$I_{o1} = gm(V_1 - V_2) = gm_1(V_a - V_{o1})$$

$$V_{c1} = I_{o1} \times C_1 + V_b = \frac{gm_1}{sC_1 + gm_1} V_b$$

$$I_{o2} = gm_2(V_1 - V_2) = gm_2\left(\frac{gm_1}{sC_1 + gm_1} V_b - V_{o1}\right)$$

$$V_{o2} = \frac{gm_2}{sC_2 + gm_2} I_{o2} + V_c$$

Substituting I_{o1} and I_{o2} from above,

$$V_{o1} = \frac{gm_1}{sC_1 + gm_1} (V_a - V_{o1}) + \frac{gm_2}{sC_2 + gm_2} \left(\frac{gm_1}{sC_1 + gm_1} V_b - V_{o1} \right) + V_c$$

Rearranging and solving,

$$V_{o1} = \frac{gm_1 V_a + \frac{gm_1 gm_2}{sC_1 + gm_1} V_b + (sC_2 + gm_2) V_c}{s^2 C_1 C_2 + s(gm_1 C_2 + gm_2 C_1) + gm_1 gm_2}$$

Let,

$V_i = V_a$ and have V_b and V_c are grounded.

Set $gm_1 = gm_2 = gm$

Divided by $C_1 C_2$ in both numerator and denominator.

$$\frac{V_o}{V_i} = \frac{gm V_a + \frac{gm^2}{sC_1 + gm} V_b + (sC_2 + gm) V_c}{s^2 C_1 C_2 + s(gm C_2 + gm C_1) + gm^2}$$

This expression can be written as :

$$\frac{V_o}{V_i} = \frac{gm V_a + \frac{gm^2}{sC_1 + gm} V_b + (sC_2 + gm) V_c}{s^2 C_1 C_2 + s(gm C_2 + gm C_1) + gm^2}$$

Therefore, it represents a low pass filter whose critical frequency is

$$f_o = \frac{1}{2\pi\sqrt{C_1 C_2}}$$

and $Q = \frac{gm}{C_1 + C_2}$

By selective grounding of any two of the terminals of input voltages (V_a, V_b, V_c), low pass, high pass, band pass and band reject (notch filter) responses can be realized:

1. LOW PASS FILTER -- It passes the signal at lower frequency and then has a certain cutoff frequency, in this filter the cutoff frequency is less than the signal frequency. The frequency response curve of LPF depends on the design. LPF provide regular form of the signal. It has a wide range of application such as audio amplifier, equalizer, in analog and digital conversion,

radio transmitter to block harmonic emission.

When $V_1 = V_a$; V_b and V_c are grounded, then the circuit provide low pass filter response.

2. HIGH PASS FILTER-- it passes the signal at higher frequency and then has a certain cutoff frequency, in this filter the cutoff frequency is higher than the signal frequency. The quality of attenuation for each and every frequency depend on the design. It used as radio frequency devices, it also used in colligation with a low pass filter to produce a band pass filter.

When $V_1 = V_c$; V_a and V_b are grounded, then the circuit provide high pass filter response.

3. BAND PASS FILTER--in this filter the frequency will pass within a certain range. It has a high Q factor for narrow band pass and low Q factor for wide band pass. Q factor is inversely proportional to its bandwidth. Band pass filter (BPF) mainly used in wireless transmitter and receiver, atmospheric science has an example of outside of electronic and signal processing. When $V_1 = V_b$; V_a and V_c is grounded, then the circuit provide band pass filter response.

4. BAND REJECT FILTER-- in this filter they pass most frequency invariable, it reduces particular range to very low level. a notch filter is a band stop filter with a narrow stop band filter. it has a high Q factor. It is used in raman spectroscopy, PA system instrument amplifier. It have a many names like band limit filter, T-notch filter band elimination filter and narrow notch filter.

When $V_1 = V_c = V_a$ and V_b are grounded, then the circuit provide band reject filter response.

IV. DESIGN, CALCULATION AND SIMULATION RESULTS

In this paper the proposed circuit is designed on 20 KHz. frequency. By changing the transconductance G_m , frequency can be varied without changing the component values.

Design steps:

1. Choose the cutoff frequency, $F_o = 20\text{KHz}$

2. Calculate $gm = \frac{I_c}{2V_T}$

$$I_c = 0.1\mu\text{A TO } 400\mu\text{A}$$

1. LOW PASS FILTER (LPF):-

LPF AT 20KHZ

$$G_m = 10\text{nA/V}$$

$$C = 0.07\text{Pf}$$

In this circuit, $V_i = V_a$; V_b and V_c are grounded

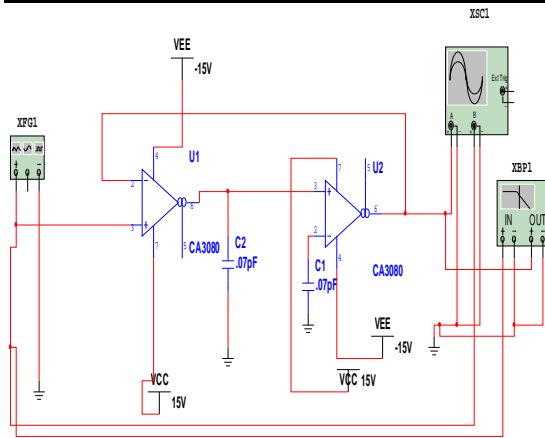

Fig. 1: LPF circuit



Fig.1(c): input from function generator for LPF circuit

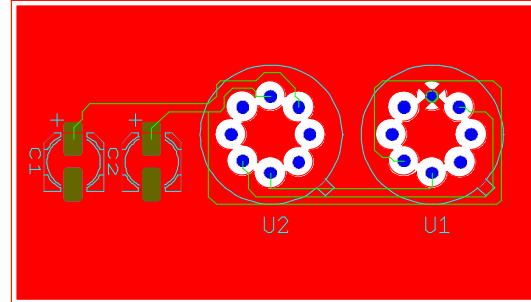

Fig.1(d): PCB layout using Ultiboard of LPF

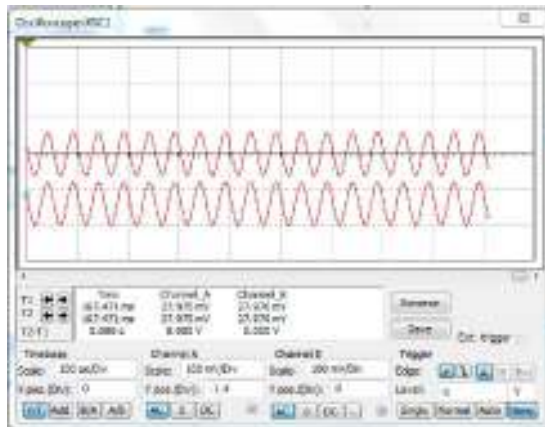

Fig.1(a): output waveform of LPF circuit

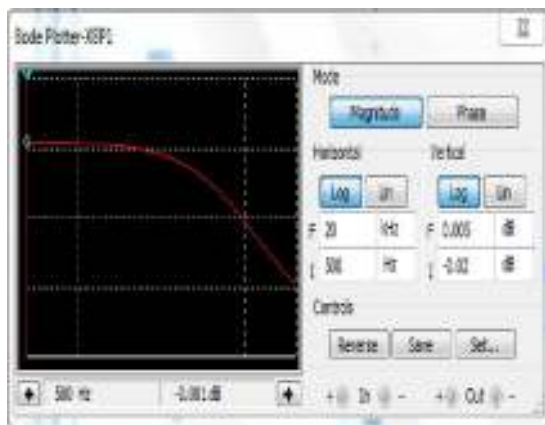

Fig.1(b): frequency response curve of LPF circuit

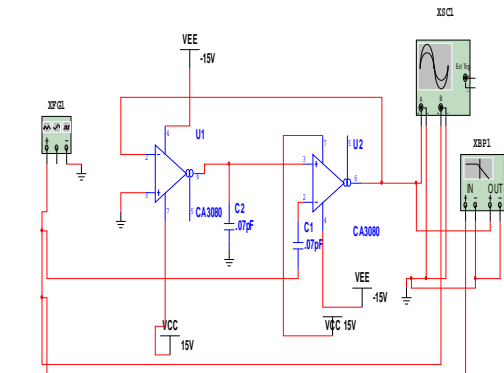

Fig 2. :HPF circuit

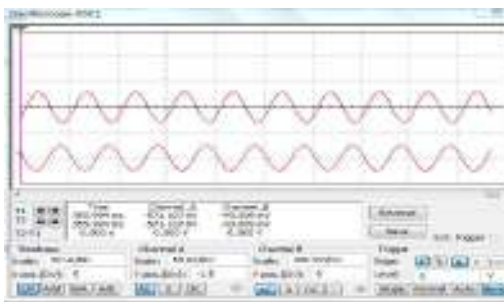

Fig.2(a): output waveform of HPF circuit

2. HPF :-In this circuit $V_i = V_c$; V_a and V_b are grounded .



Fig.2(b): input from function generator for HPF circuit

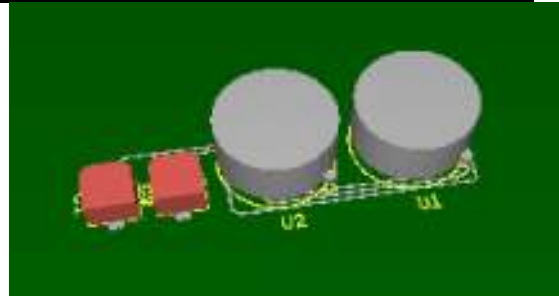

Fig.2(f): 3-D view of HPF circuit

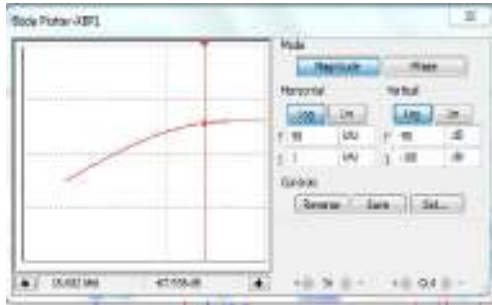

Fig.2(c): frequency response curve of HPF circuit

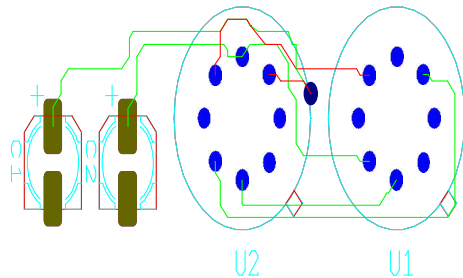

Fig.2(d): ultiboard design of HPF circuit

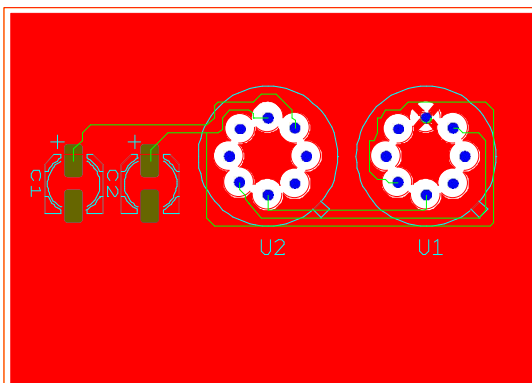

Fig.2(e):PCB layout using Ultiboard of HPF

3. Band pass filter: In this $V_i = V_b$; V_a and V_c are grounded.

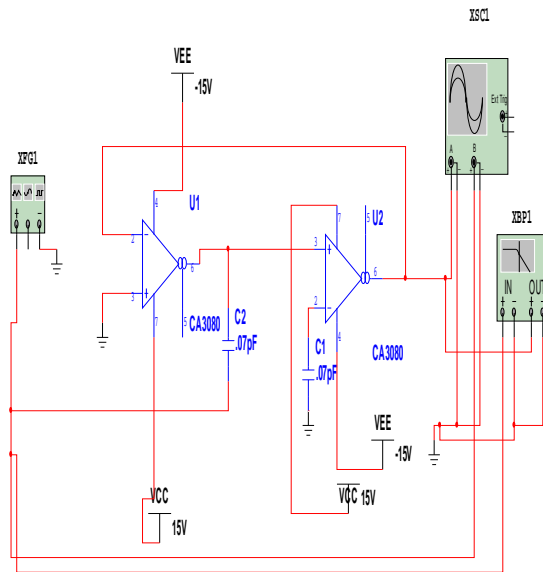

Fig.3 : BPF circuit

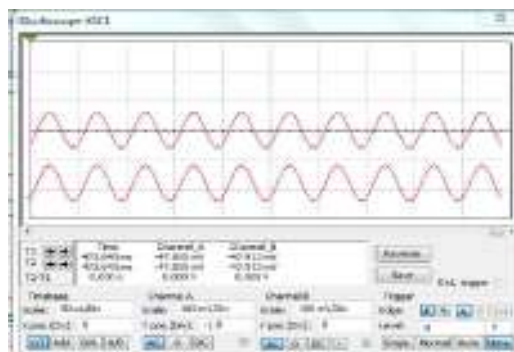

Fig.3 (a): output waveform of BPF circuit

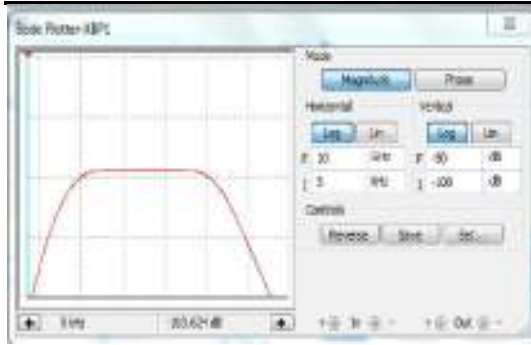

Fig.3(b): frequency response curve of BPF circuit

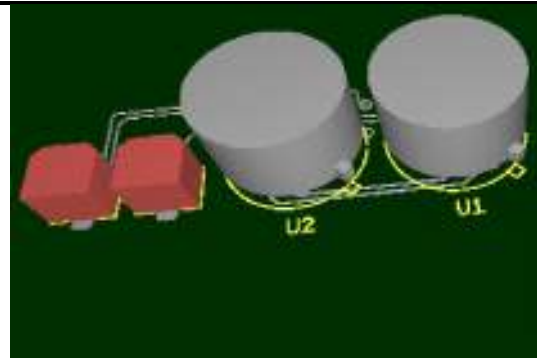

Fig.3(e): 3-D view of BPF circuit

4. Band reject filter: In this $V_i = V_a = V_c$; V_b is grounded .

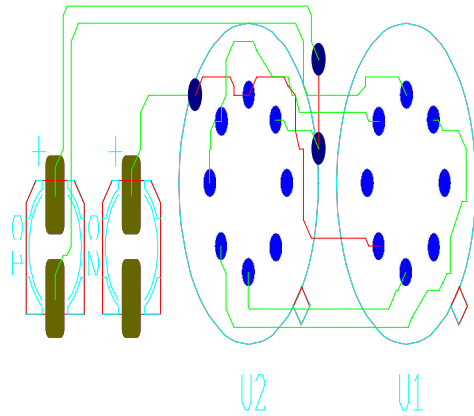

Fig.3(c): ultiboard design of BPF circuit

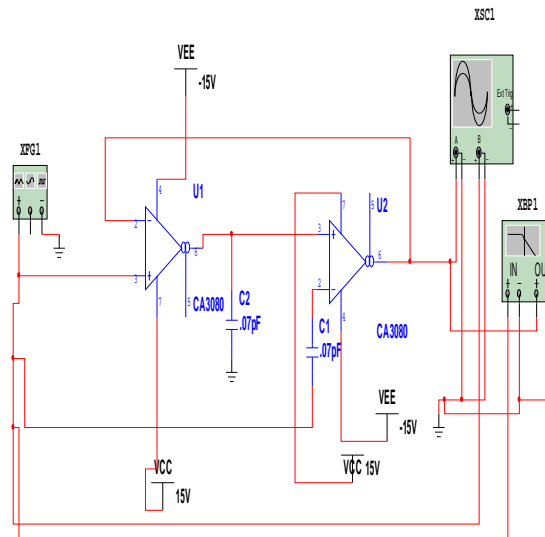

Fig.4: BRF circuit

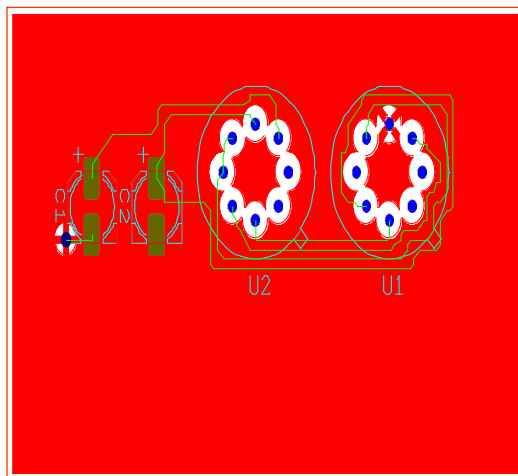

Fig.3(d): PCB layout using Ultiboard of BPF



Fig.4(a): frequency response curve of BRF circuit

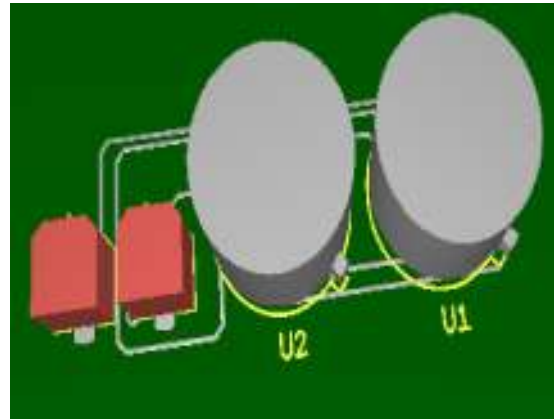

Fig.4(d): 3-D view of BRF

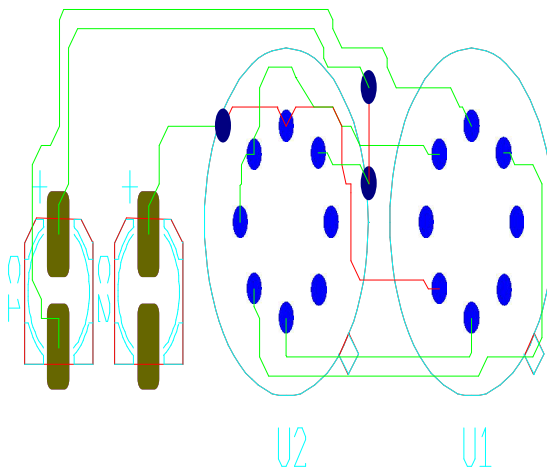

Fig.4(b): ultiboard design of BRF circuit

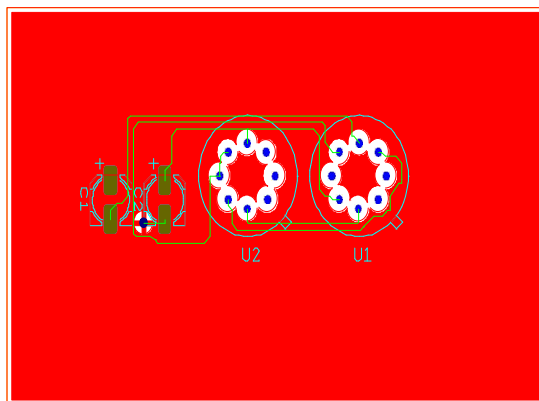

Fig.4(c): PCB layout using Ultiboard of BRF

CONCLUSION

OTA based second order active filter which realizes Low pass filter, High pass, Band pass and Band reject filters has been presented in this paper. The proposed MISO type circuit has been designed using CA3080 IC on 20 KHz frequency so that it can be suitable for audio frequency ranges (0-20 KHz) by changing the transconductance g_m without disturbing the other component value and the peak to peak voltage is used 30 mV. Because of some limitations of CA3080 IC such as slew rate is 50 v/ μ s, other OTA based IC also used for better results and higher frequency ranges such as LM13600, LM13700 from national semiconductor and NE5517 from signetics. We concluded that the OTA based circuit designs are very simple in comparative to other analog building blocks because they requires few components only. In comparative to other RC active filter, OTA based circuitry requires no resistors. Using two OTA and two capacitor the circuit provides good frequency response curve of all active filters. Simulation results and PCB Layout, 3-D View have been shown so that it can be implemented on hardware.

REFERENCES

- [1] Rahul Kumar et al , " Design of Biquad Universal Filter Using Operational Transconductance Amplifier in 180nm Technology", Int. Journal of Engineering Research and Applications, ISSN : 2248-9622, Vol. 4, Issue 5(Version 2), May 2014, pp.120-125
- [2] Ghanshyam Singh, D. R. Bhaskar, Dinesh Prasad, "Three-Input One-Output Voltage-mode MISO-Type Biquad using OTAs", International Journal of Electronics, Electrical and Computational System IJECS, ISSN 2348-117X Volume 4, Special Issue March 2015
- [3] Rajeshwari S. Mathad, M. M. Mutsaddi, Manjula V. Katageri, Realization of OTA-C Universal Filter Based on Q- Factor ", Proc. of The Third Intl. Conf. on Advances in Computing, Electronics and Communication - ACEC 2015 Copyright © Institute of Research Engineers and Doctors, USA .All rights reserved. ISBN: 978-1-63248-064-4 doi: 10.15224/ 978-1-63248-064-4-26



[4] Manish Gupta, "New Single Input Multiple Output Type Current Mode Biquad Filter Using OTAs", Circuits and Systems, 2016, 7, 231-238 Published Online April 2016 in SciRes., <http://dx.doi.org/10.4236/cs.2016.74022>

Author's detail

Vijay Laxmi Kalyani, Assistant Professor and Former H.O.D of ECE department, Govt. Women Engineering College, Ajmer.

Vartika Gupta, B. Tech, EEE (III-year), Govt. Women Engineering College, Ajmer.

Harshita Khandelwal, B. Tech, EEE (III-year), Govt. Women Engineering College, Ajmer.

Teena, B. Tech, EEE (III-year), Govt. Women Engineering College, Ajmer.