



CFOA Based Active Universal Filter Realized With Multiple Feedback Filter, Low- Pass Filter and High Pass Filter

Vijay Laxmi Kalyani, Taruna Kanwar, Sweety Kalwani

DOI 10.5281/zenodo.1302413

Vijay Laxmi Kalyani,, Assistant Professor and former HOD, Govt. Women Engineering College Ajmer, India
vijaylaxmikalyani@yahoo.com

Taruna kanwar, B.Tech III-Year, (ECE), Govt. Women Engineering College Ajmer, India
tarunakanwar4@gmail.com

Sweety kalwani, B.Tech, III-Year, (ECE), Govt. Women Engineering College Ajmer, India
Sweetykalwani5510@gmail.com

ABSTRACT: -In this paper, CFOA based Universal Filters design is presented which is the combination of narrow band pass filter (multiple feedback filter), Low pass filter and High pass filter. The proposed circuit realizes all the standard of frequency responses of universal filter. The proposed circuit uses narrow band pass filter so that the frequency response will be sharper and value of Q (quality factor) will be higher. It also uses low pass filter to select low frequency signals and high pass filter to passes high frequency signals only. The proposed circuit designed using AD844 IC that can be helpful in getting accurate response in different applications of filter and work for high frequency applications. The frequency range used here is in MHz to GHz. Simulation results and analysis have been carried out using NI-multisim software. Ultiboard results and 3D layout are also shown of the proposed circuit.

Keywords: Universal filter (multiple feedback filter, Low pass filter and High pass filter), AD844 CFOA IC, NI-multisim, ultiboard

I. INTRODUCTION

With the advancement in Integrated Circuit technology, a number of manufacturers design many types of universal filters having simultaneous low-pass, high-pass, and bandpass output responses. These types of filters are called universal filter. These filters provide the gain and Q-factor. The Q-factor is called as Quality factor and it is used to measure selectivity. Thus, higher the value of Q means the more selective is the filter. The Q-factor is known from resonant circuits. The Q-factor is the relation between center frequency and bandwidth. Universal filters are used to remove the unwanted signals and we get good quality of information. Nowadays with the increase in wireless technology in many applications such as radio, satellite system, mobile phones etc. for sharing of audio, video and digital information everyone needs a good quality of information which can only be obtained by using filters (universal filters) to remove unwanted signals and get the good quality of data and signals. Although, various design of universal filter using CFOA have been proposed by the researchers [1-5]. In [1], Biquad Filter was proposed with three CFOA. In [2], a voltage-mode programmable active-RC filter employing four Current-Feedback Operational

Amplifiers (CFOAs), one dual CMOS digital potentiometer, seven virtually grounded resistors and two grounded capacitors was presented. In [3], Voltage-mode universal filters using two current conveyor was presented which can realize using low-pass, band-pass, high-pass, notch and all-pass filters.

In this paper, the author(s) have made an effort in designing Universal Filters which is the combination of multiple feedback filter (Narrow band pass filter), Low pass filter and High pass filter. The proposed universal filter is based on CFOA (current feedback operational amplifier). The proposed circuit designed using AD844 (CFOA based IC) that can be helpful in getting accurate response in different applications of filter and work for high frequency applications. The frequency range used here is in MHz to GHz range.

II. PROPOSED CIRCUIT OF UNIVERSAL FILTER

current feedback operational amplifier have many advantages in analog circuit design such as, gain-bandwidth independence, higher slew rate (typically 2,000 v/ μ s) and it can operate on higher frequency range of operation. Therefore in this paper the proposed design based on CFOA so that we can use for higher frequency application. Proposed CFOA based Universal Filters design is the combination of narrow band pass filter (multiple feedback filter), Low pass filter and High pass filter. The proposed circuit realizes all the standard of frequency responses of universal filter. The proposed circuit uses narrow band pass filter so that the frequency response will be sharper and value of Q (quality factor) will be higher and a high pass filter so that it can passes the high range of frequencies only and blocks the low frequencies and Low pass filter is also used so that only low frequencies can be passes and it blocks the higher frequency ranges. Therefore we can use this universal filter for different types of applications such as PLL (phase locked loop), Loud speakers, FM stereo demodulator etc. for a particular higher frequency range.

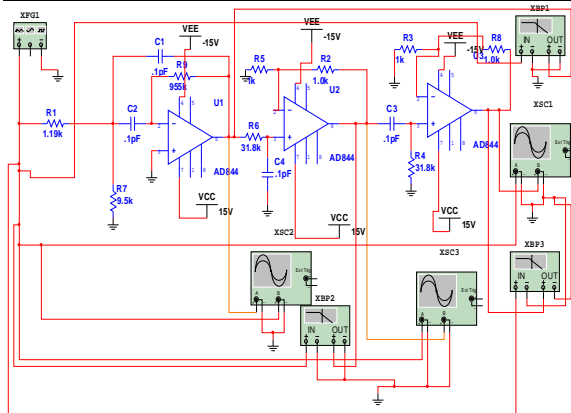

Fig. 1: CFOA based universal filter design using AD844 IC



Fig.2: Input from function generator

III. SIMULATION RESULTS AND ANALYSIS

The proposed universal filter circuit is the combination of narrow band pass filter, Low pass filter and high pass filter.

III.I. Narrow band pass filter design:

Narrow band pass filter is also referred as multiple feedback filter. The design parameters are:

$$R_1 = Q/2 \cdot F_c \cdot A_f$$

$$R_7 = Q/2 \cdot F_c (2R^2 - A_f)$$

$$R_9 = Q/ F_c \cdot C$$

Where,

A_f is gain at F_c

Given by,

$$A_f = R_3/2R_1 \text{ and } F_c = (F_H F_L)^{1/2}$$

To design the narrow band pass filter assume the cut off frequency 50 MHz, $Q=15, A_f=400$

Choose the value of capacitor $C_1=C_2=C=0.1\text{PF}$ then calculate the value of $R_1=1.19\text{K}$, $R_7=9.5\text{K}$, $R_9=955\text{K}$

The resonant frequency can be changed in this filter by adjusting R_7 without changing the bandwidth or gain. The bandwidth (B.W.) is determined by R_1C .

Therefore $B.W. = 0.1591/R_1C = 1.3 \text{ GHz}$ and the resonant frequency $f_r = 0.1125/RC = 0.9 \text{ GHz}$

III.II. Output of Narrow band pass filter

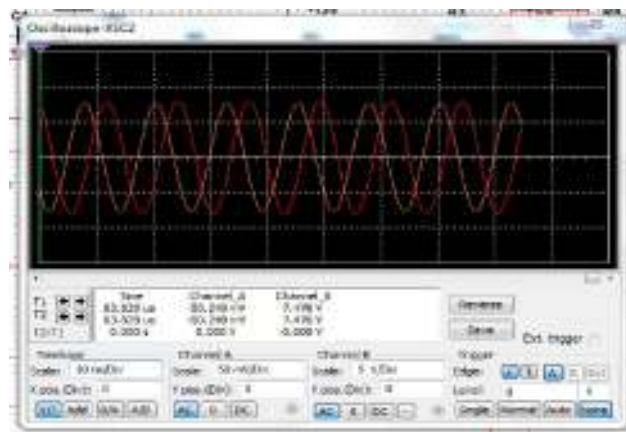

Fig.3: output waveform of narrow band pass filter

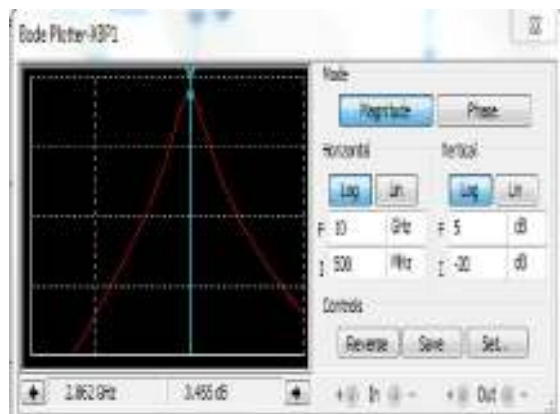

Fig.4: frequency response curve of narrow band pass filter using bode plotter

When we apply the input frequency 80 MHz then the output results obtain in form of sine wave (shown in fig.3) and the frequency response curve also determined with accurate results (fig.4). frequency response curve shows that there is narrower bandwidth and the center frequency is 2.8 GHz which is near to theoretical value. The low cut off frequency show in fig.4 is 2.27 GHz and high cut off frequency is 3.52 GHz. Therefore the bandwidth is 1.25 GHz which is near to the theoretical value (1.3 GHz).



III.II. Output of Low pass filter

Low pass filter allows only low frequency signals upto a certain high cut off frequency f_H . Where $f_H=1/2 RC$
To design this filter first select the high cut off frequency $f_H=50\text{MHz}$
Choose the value of $C=C_4=0.1\text{PF}$ and $R_6=31.8\text{K}$, $R_8=R_2=1\text{K}$.

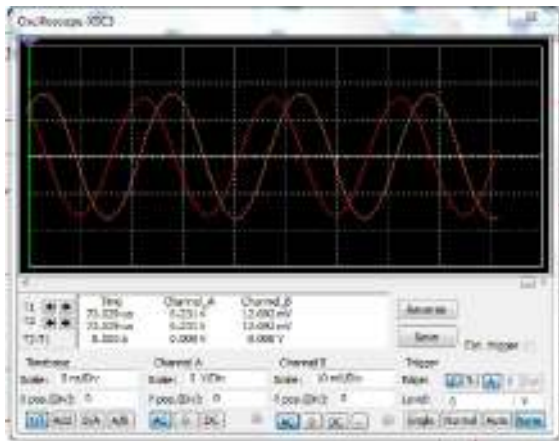

Fig.5: input and output waveform of Low pass filter

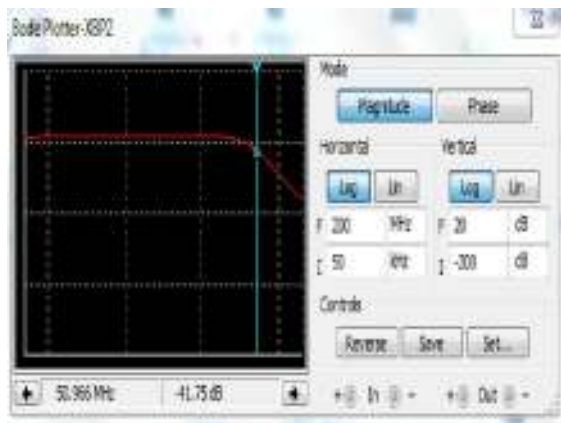

Fig.6: frequency response curve of Low pass filter using bode plotter

The output of the low pass filter is shown in fig.5 in form of sinewave. The frequency response curve shown in fig.6 provide the curve at high cut off frequency 50.966 MHz which is near to the theoretical value.

III.III. Output of High pass filter:

High pass filter passes only high frequency signal.
To design the high pass filter first choose the low cut off frequency $f_L=50\text{MHz}$ (Where $f_L=1/2 RC$).

Select the value of $C=C_3=0.1\text{PF}$ and then calculate the value of $R_4=31.8\text{K}$, $R_8=R_8=1\text{K}$.

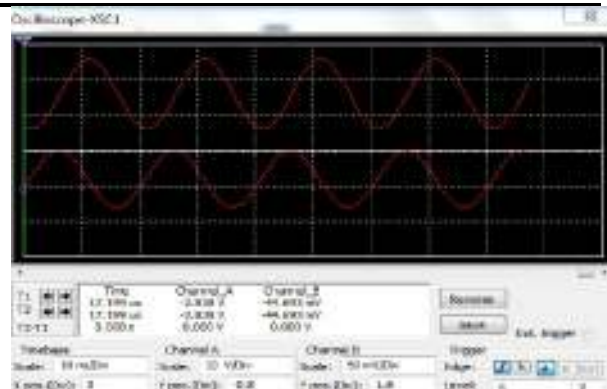

Fig.7: Input and output waveform of High pass filter

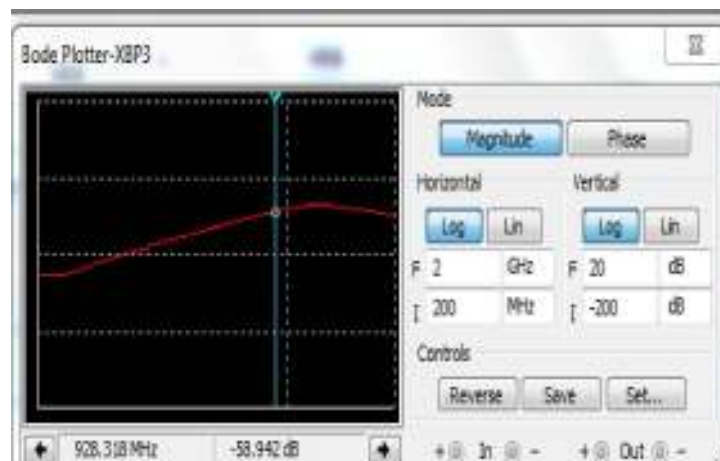

Fig.8: Frequency response curve of High pass filter using bode plotter
Fig.7 shows the output results in form of sine wave and fig.8 shows the frequency response curve at cut off frequency 928.318 MHz.

III.IV. Ultiboard design of the circuit:

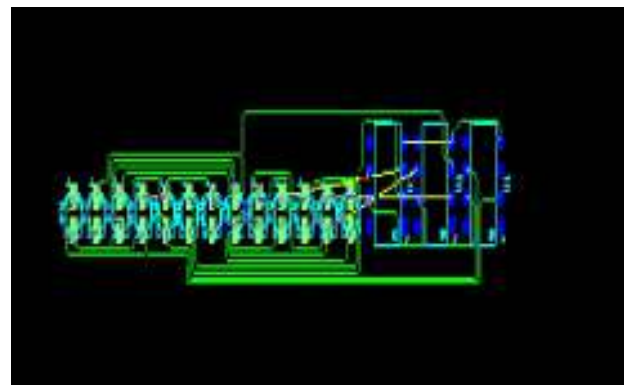

Fig.9: Ultiboard layout of universal filter



III.V.PCB Layout of the circuit:

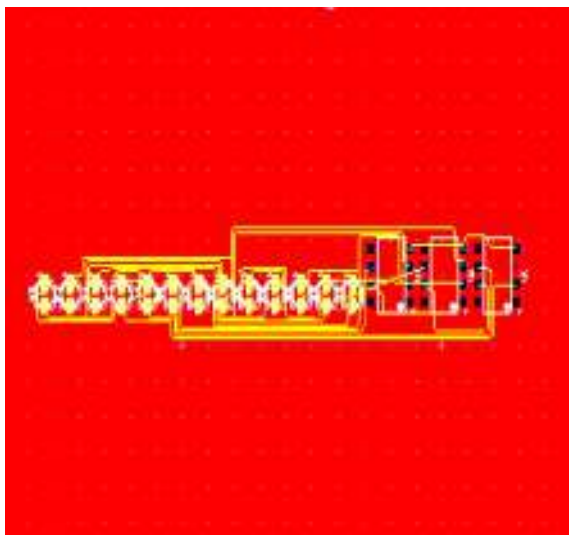

Fig.10: PCB Layout of the universal filter circuit

III.VI. 3D View of the circuit:

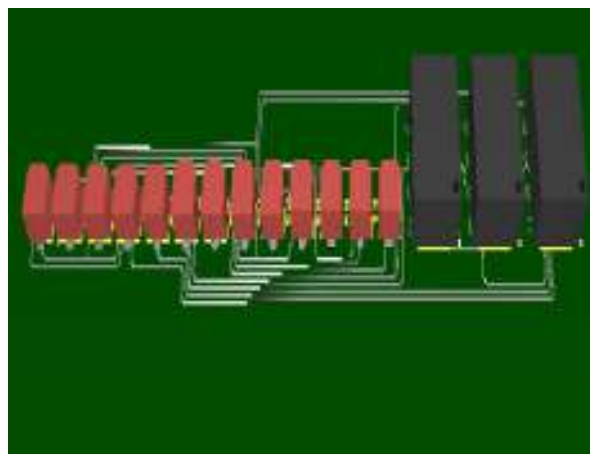

Fig.11: 3D View of the universal filter circuit

CONCLUSION

The new design of universal filter based on CFOA has been introduced in this paper. The proposed universal filter is the combination of narrow band pass filter (multiple feedback filter), Low pass filter and high pass filter. Because the multiple feedback filter is the unique filter among all filters therefore design of universal filter using multiple feedback filter provides the high value of Q and narrower band width. Using CFOA based design we can operate this type of circuit on a very high frequency applications and minimum number of component required in the circuitry. From the simulation results and theoretical values we can concluded that the output results of narrow band pass filter, Low pass filter and high pass filter are approximately near to the theoretical results. With the help of ultiboard and PCB design layout we can use this circuitry for hardware implementation and we can also change the frequency ranges according to the application simply by changing the value of resistance and capacitance according to the design formulas. 3D view of the circuitry are also shown for better understanding. Therefore universal filters are helpful to remove unwanted signals and get the output results at very high frequencies.

REFERENCE

- [1] Vijay Laxmi Kalyani, Lehar Kewalramani, "Biquad Filter Employing With Three CFOA And Its Application", Journal of Management Engineering and Information Technology, Volume -2, Issue- 6, Dec. 2015, ISSN: 2394 - 8124
- [2] Ivailo Milanov Pandiev, "Voltage-mode Lowpass, Bandpass, and Bandstop Programmable Filter using Four-terminal CFOAs", Conference: ICEST 2010, At Ohrid, Macedonia, Volume: 2
- [3] Shen-Iuan Liu & Jiin-Long Lee, "Voltage-mode universal filters using two current conveyors", International Journal of Electronics, Volume 82, 1997 - Issue 2

AUTHOR'S DESCRIPTION

VIJAY LAXMI KALYANI, Assistant Professor and former H.O.D from ECE department, Govt. Women Engineering College, Ajmer.

TARUNA KANWAR, B. tech (111 -year) in electronics and communication in GWECA

SWEETY KALWANI, B. tech (111 -year) in electronics and communication in GWECA